

Members' Briefing
137 & 143 Histon Road,
Cambridge



Cambridge
Investment
Partnership

March
2024

Content

1.0 Introduction		5.0 Architecture Development	
1.1 About Cambridge Investment Partnership	4	5.1 Build form & Features	29
2.0 Site Context		5.2 Materials & Precedents	30
2.1 Site Location	6	5.3 Design Developments – Apartment	31
2.2 Wider Context	7	6.0 Landscape	
2.3 Planning Context	8	6.1 Design Concept	35
2.4 Site photos	9	6.2 Concept Design - Development Area	36
2.5 Surrounding Heights & Uses	12	6.3 Landscape Proposals - Development Area	37
2.6 Figure Ground Analysis	13	6.4 Tree planting - Development Area	38
2.7 Architectural Context Analysis	15	6.5 Hard landscape - Development Area	39
2.8 Constrains & Opportunities	16	6.6 Concept Design - Recreation Ground (North)	40
3.0 Design Development		6.7 Concept Design - Recreation Ground (South)	41
3.1 Design Drivers - 4Cs	18	6.8 Landscape proposals - Recreation Ground	42
3.2 Design Concepts	19	7.0 Strategies	
3.3 Layout Development	21	7.1 Parking	44
3.4 Design Principles	22	7.2 Refuse	46
3.5 Design Process	23	7.3 Housing Typology	47
4.0 The Proposal		7.4 Tenure	48
4.1 Proposed Layout - Summary	25	7.5 Building Relations	54
4.2 Movement & Connectivity	26	7.6 Street & 3D views	57
4.3 Sustainability Principles	27	7.7 Trees	60
		7.8 Drainage	61
		8.0 Conclusion	

1.0 INTRODUCTION

1.1 About Cambridge Investment Partnership

4

1.1 CAMBRIDGE INVESTMENT PARTNERSHIP

137 & 143 Histon Road will be developed by Cambridge Investment Partnership (CIP) which is an equal partnership between Cambridge City Council and Hill Investment Partnerships.

CIP is supporting the Council to deliver new affordable homes across the city by developing council-owned land and other sites. The Partnership model allows the joint investment of land, funding and professional expertise in housing and mixed-use development.

CIP is focused on tackling Cambridge's affordable housing shortage, optimising value for the Council whilst promoting excellence in design and placemaking.

Partnership Objectives:

- To create environmentally and socially sustainable new places to live in Cambridge.
- Improve the use of council assets and those of other public sector bodies in Cambridge to meet the identified housing need across the city.
- Deliver 1,000 net new affordable homes in Cambridge through the partnership.
- Achieve high environmental standards for new homes with all future developments to be gas-free and designed with sustainable standards and principles (such as fabric first, minimising cold bridging, maximising daylight sunlight and cross ventilation, etc)



FEN ROAD, CAMBRIDGE



ARAGON & SACKVILLE CLOSE, CAMBRIDGE



MILL ROAD, CAMBRIDGE



CROMWELL ROAD, CAMBRIDGE

2.0 CONTEXT

2.1 Site Location	6
2.2 Wider Context	7
2.3 Planning Context	8
2.4 Site photos	9
2.5 Surrounding Heights & Uses	12
2.6 Figure Ground Analysis	13
2.7 Architectural Context Analysis	14
2.8 Constrains & Opportunities	16

2.1 SITE LOCATION

The site is located to the west of Histon Road, which is one of the main arterial roads to the north of Cambridge and is situated around 1 mile from the city centre. The site extends to approximately 1.18 hectares and comprises vacant buildings that were previously occupied by Murketts car dealership and an unused workshop area of the ATS commercial unit.

The proposed site is framed by 3-storey houses along its western boundary (Seaby's Yard) and is located adjacent to Histon Road Recreation Ground in the south. On the northern side, it features three-story high student accommodations known as the "Master's House" and three 3-storey apartment blocks called "Greengate Court." ATS tyre & car services still operate at the north-east corner.

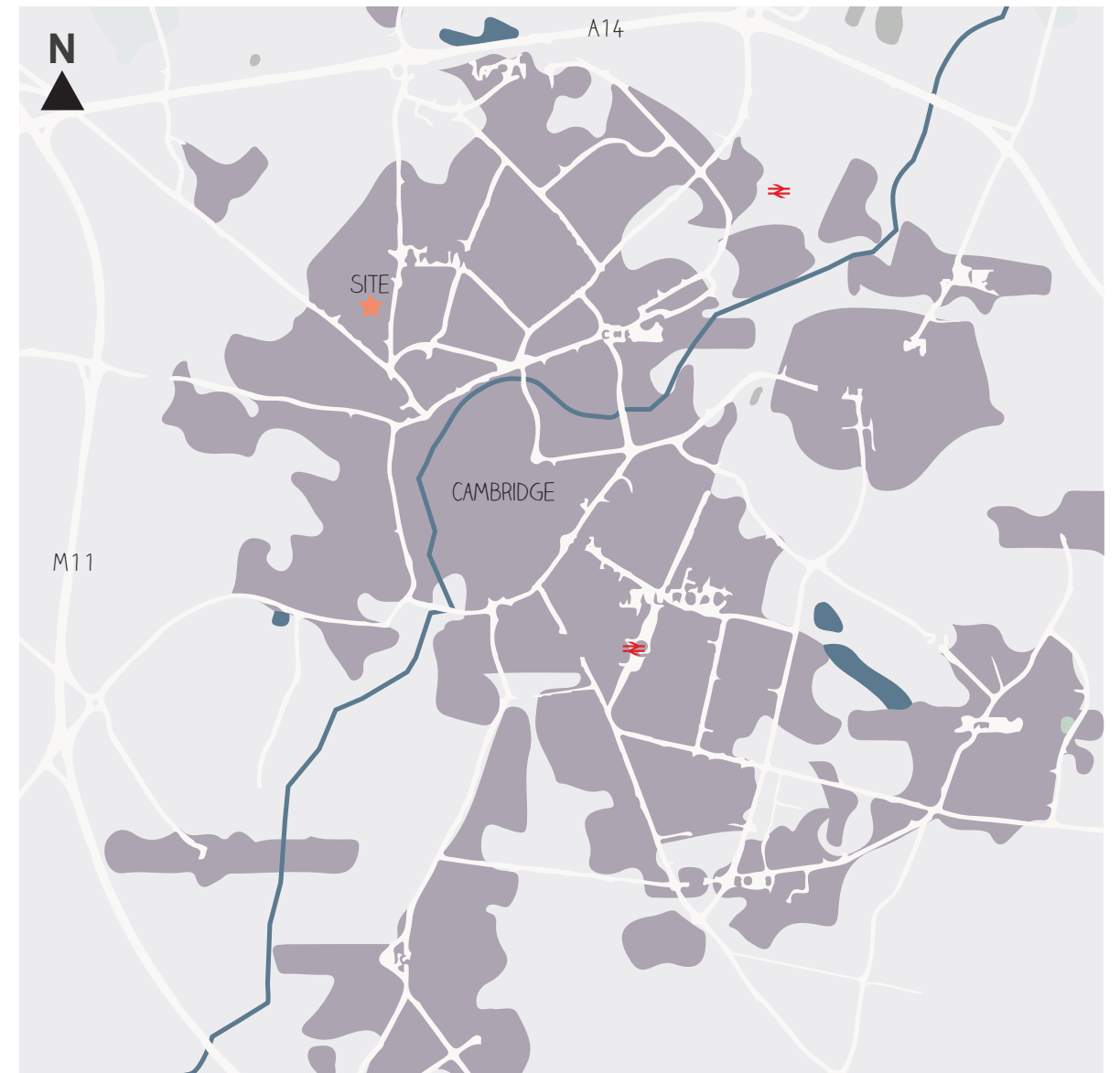







2.2 WIDER CONTEXT

The site is situated approximately 1 mile from the city centre, offering the advantage of easy access to a wide range of amenities within a short distance. Some of these amenities have been identified and are indicated on the accompanying plan, which highlights the facilities available within a 5-10 minute walk.

Furthermore, the Histon Road Recreation Ground, situated to the south of the site, offers immediate access to a pleasant green space for leisure activities including play ground, small football and a basketball court and providing a beautiful backdrop to the proposed development.

The site is also within walking distance of several local shops. The proximity of local shops to the site further enhances its appeal as a sustainable and convenient location for development.

The site benefits from excellent public transportation links, including frequent bus services that connect Histon Road to the city centre and other parts of Cambridge. There are also several cycle lanes present along Histon Road, making it an easy and safe commute for cyclists. The sustainable travel opportunities from the site and the site location close to local amenities will encourage reduction in car use.

-  Site
-  Nearest Bus Stop
-  Nearest Supermarket/Grocery Shop
-  Nearest School
-  Nearest Doctor's Surgery
-  Existing Cycle Routes
-  Public Green Spaces



2.3 PLANNING CONTEXT

The site forms part of an allocation in the Local Plan 2018 (site ref. R2) for residential development for an indicative 78 dwellings. Under current plans we are proposing the development of c. 70 homes at this site, which allows for a mix of homes, including houses and apartments and enhanced landscaping throughout the development which is considered a positive aspect of the proposals.

Key

- Cambridge City Boundary
- Conservation Area
- Protected Open Space
- Open Space - North West Cambridge Area Action Plan
- Site of Special Scientific Interest
- City Wildlife, County Wildlife and Local Nature Reserve
- Green Belt
- Strategic District Heating Area
- Cambridge Airport Public Safety Zone
- City Centre
- Primary Shopping Frontage
- Secondary Shopping Frontage
- Primary Shopping Area
- District, Local or Neighbourhood Centre
- Protected Industrial Site
- Indicative Boundary of National Geological Interest (inc. 10m buffer)
- Proposal Site
- Major Development - North West Cambridge Area Action Plan
- City Safeguarded Land
- Opportunity Area
- Area of Major Change
- Area Action Plan
- MINERAL AND WASTE SAFEGUARDING**
- Mineral Safeguarding Area - Sand and Gravel
- Allocation
- Area of Search
- Existing Site
- Transport Safeguarding Area
- Waste Consultation Area
- Waste Water Treatment Works Safeguarding Area

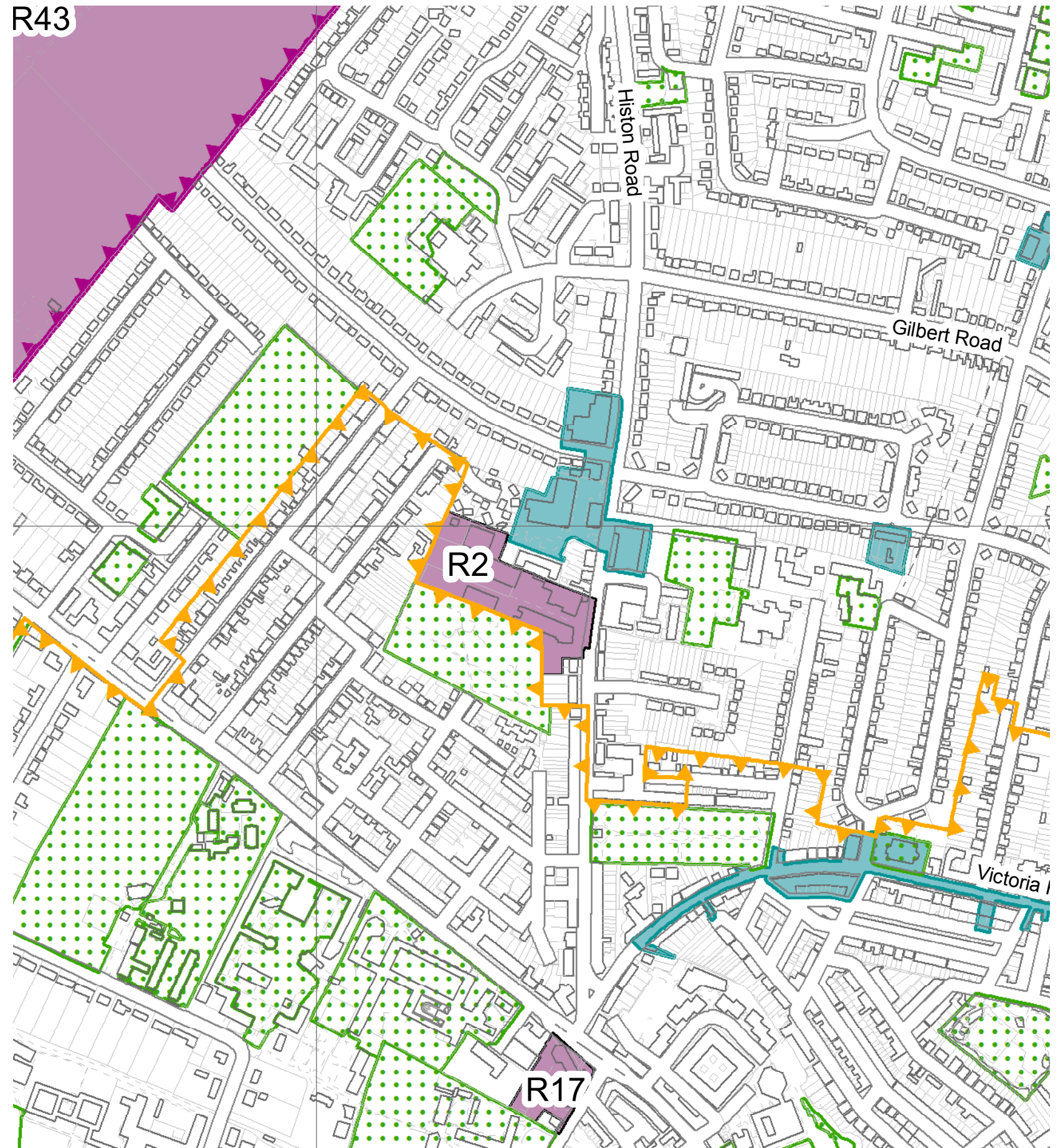

2.4 SITE PHOTOS

Our visit to site has enabled us to gain an impression of the current buildings and context on site and in the surroundings.



1 - HISTON ROAD FRONTAGE

RED INDICATES THE EXISTING MURKETT'S BUILDINGS TO BE DEMOLISHED



2 - VIEW FROM HISTON ROAD RECREATION GROUND

RED INDICATES THE MASS OF THE EXISTING BUILDINGS

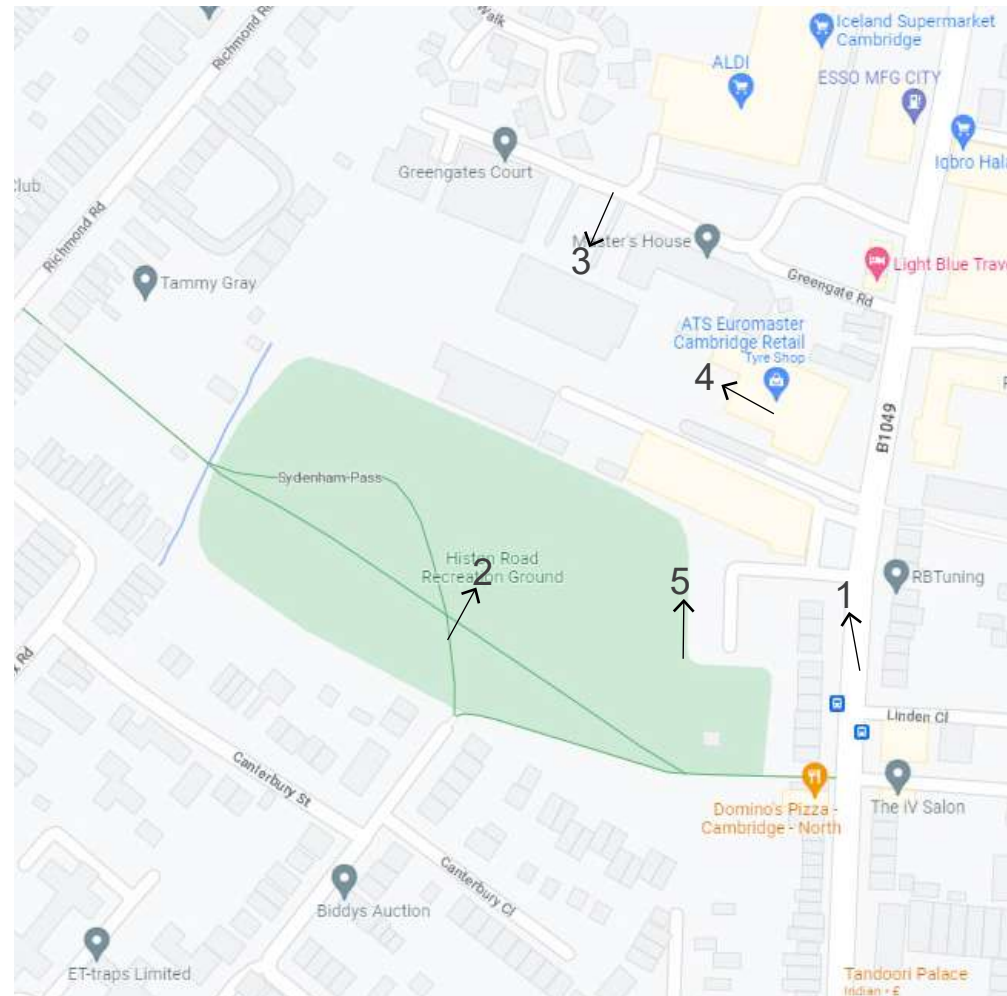

3 - VIEW FROM ALDI'S CAR PARK

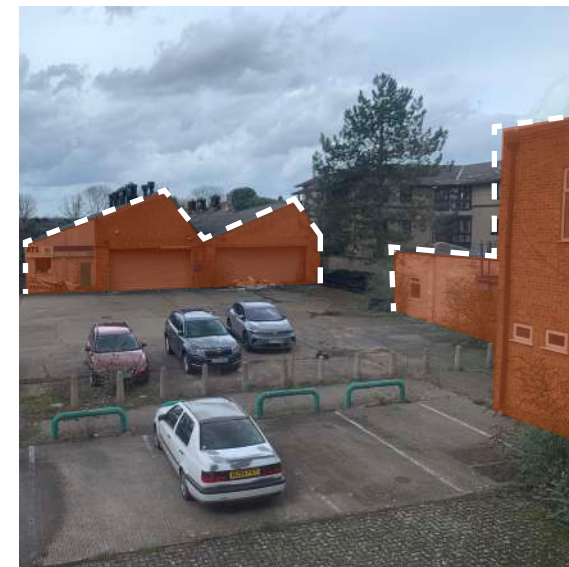

4 - EXISTING ATS BUILDINGS TO BE REMOVED



5 - VIEW FROM EASTERN EDGE OF THE PARK



11 - ATS ENTRANCE - CENTRAL TREES



6 - VIEW TOWARDS GREENGATE COURT



7 - VIEW TOWARDS SEABY'S YARD TERRACES

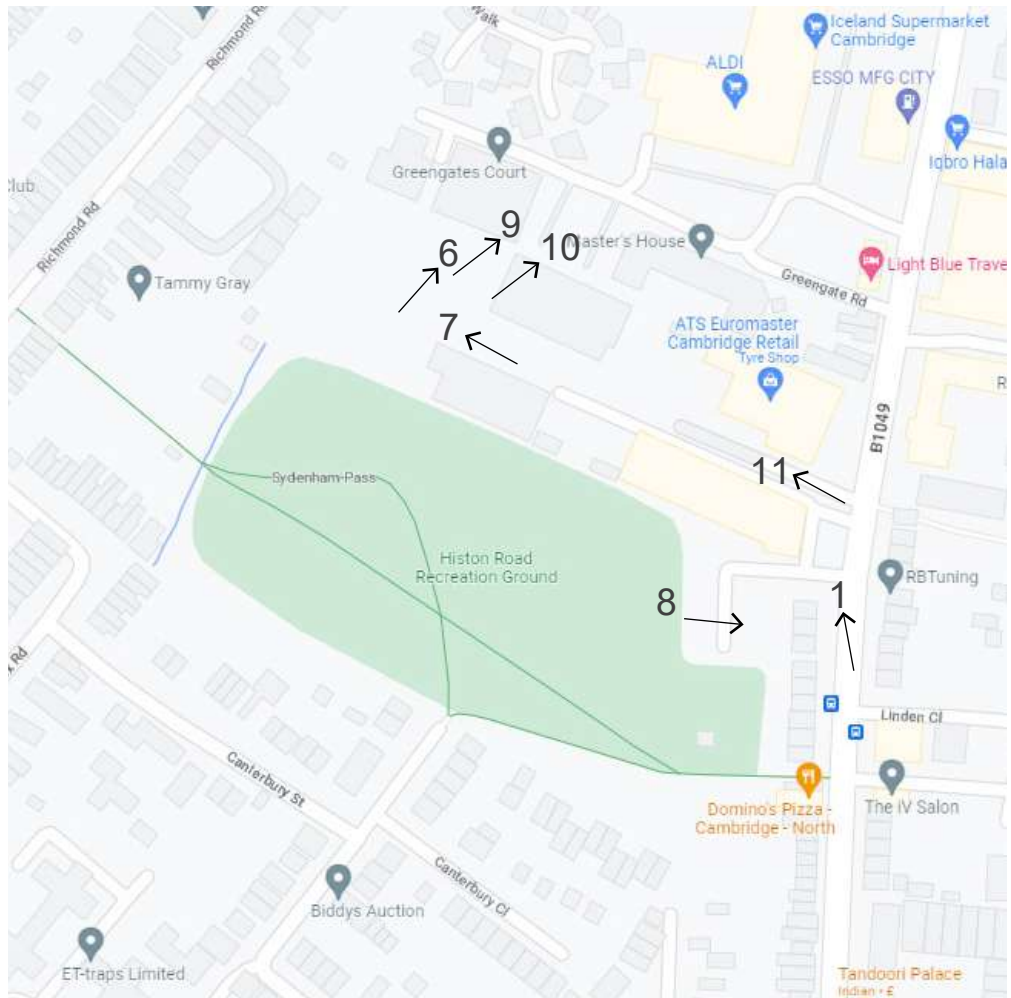

8 - REAR OF HISTON ROAD 129-133



9-149B HISTON RD REAR ELEVATION - BLOCK A



10-149B HISTON RD REAR ELEVATION - BLOCK B



12 - VIEW TOWARDS RECREATION GROUND



13 - VIEW TOWARDS RECREATION GROUND

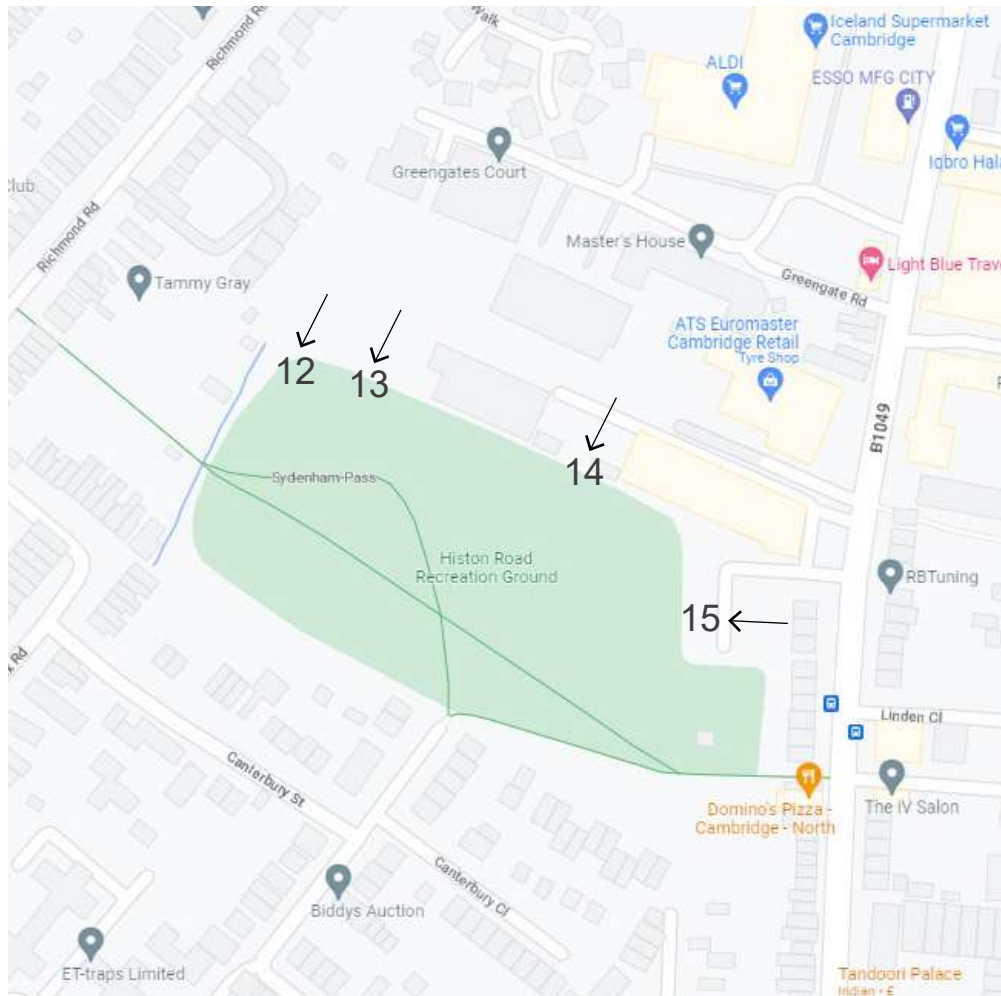

14 - VIEW TOWARDS RECREATION GROUND



15 - REAR OF HISTON ROAD 129-133 - TOWARDS RECREATION GROUND

2.5 SURROUNDING HEIGHTS & USES

The site is situated within an immediate context that comprises a mix of residential, student accommodation, and commercial units.

Residential buildings, including houses and apartments, range from two to four stories in height.

Student accommodation, typically three or five stories tall, and commercial buildings, accommodation ranging from two to three stories in height, are also present in the area.

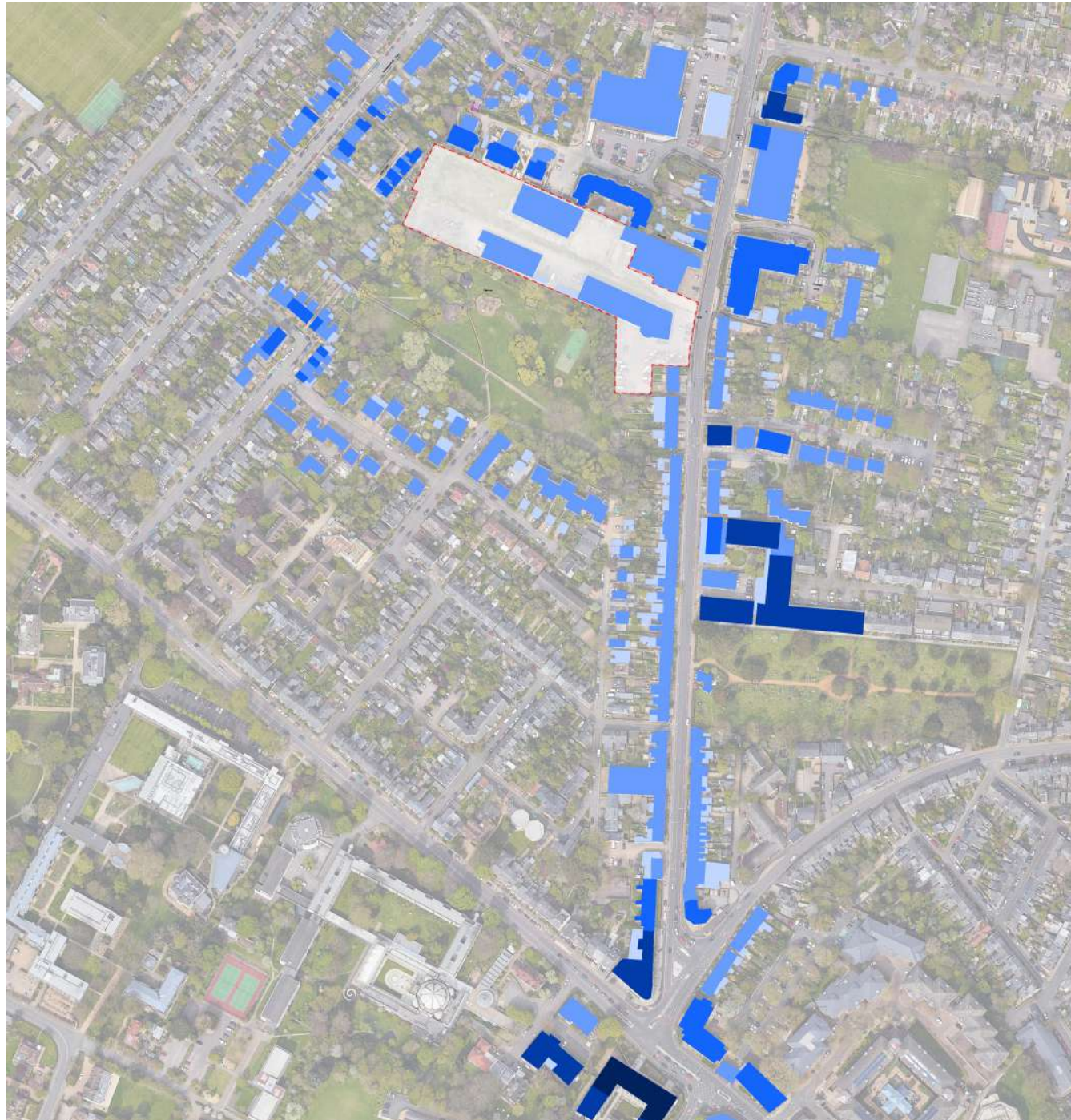

BUILDING HEIGHTS - STOREY

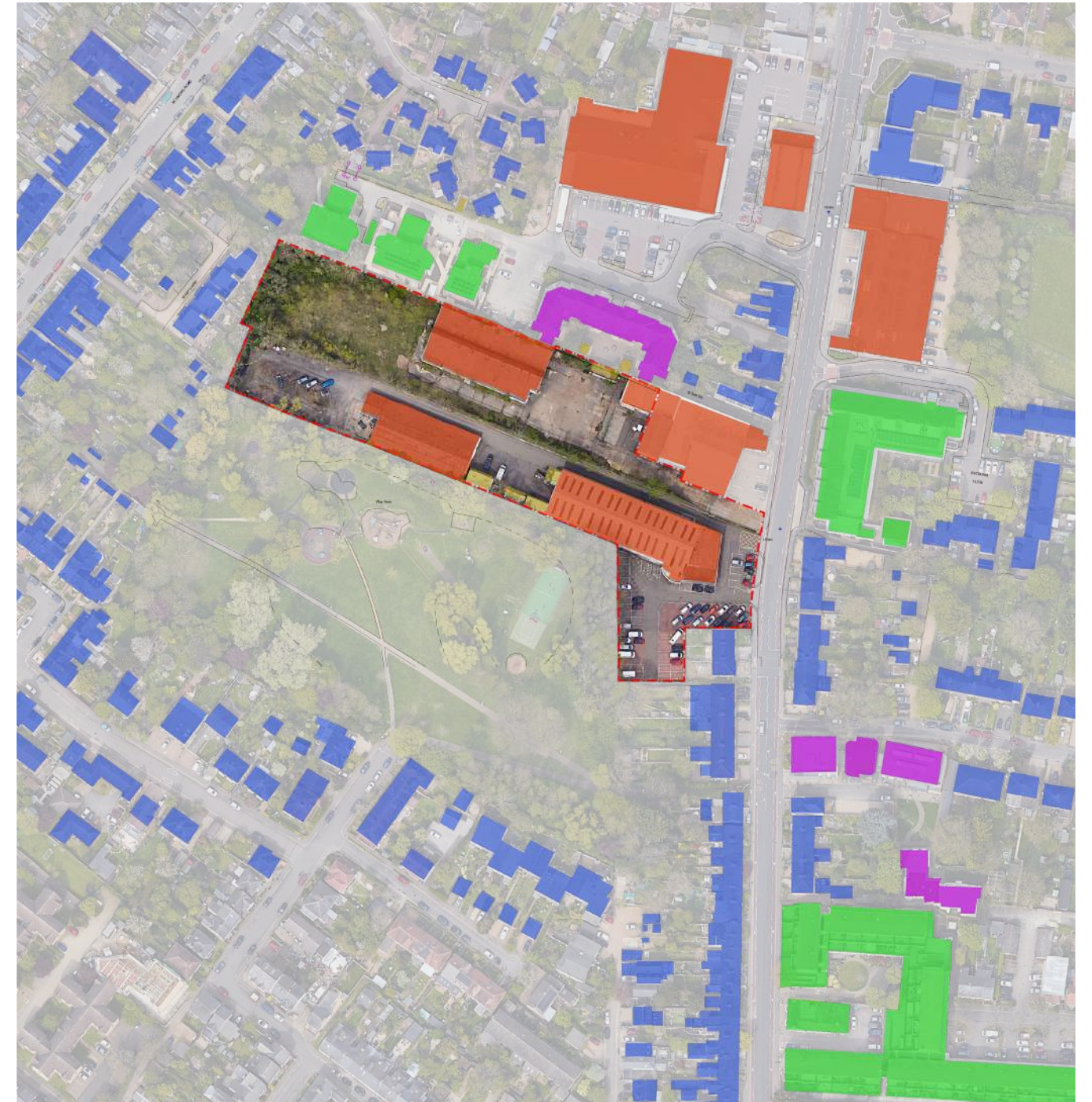

USES

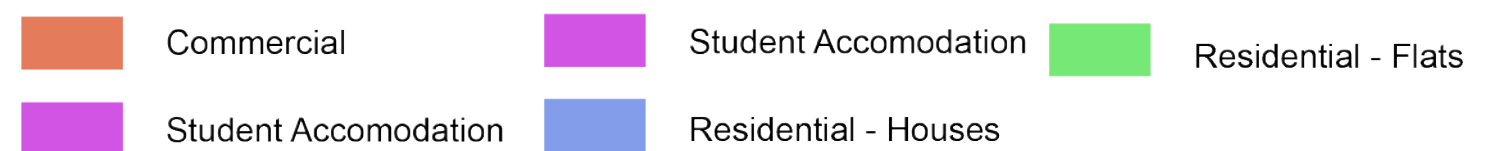

2.6 FIGURE GROUND ANALYSIS

- The site is situated near the Castle and Victoria Road conservation area, featuring predominantly two and three-story terrace and semi-detached properties.
- Within the conservation area, the arrangement of blocks and roads is characterized by straight lines and right angles at intersections
- Properties located at corners typically have flank walls.
- Front gardens along Histon Road are generally small, gradually increasing in size towards Oxford Road.
- On the Huntington Road side, Histon Road begins with four-story buildings hosting student accommodations, followed by a three-story apartment and two-storey terrace homes which most of them have to roof conversion

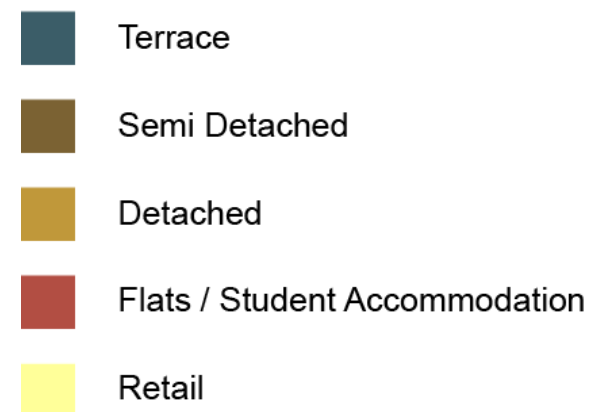

FIGURATIVE GROUND ANALYSIS

2.7 ARCHITECTURAL CONTEXT ANALYSIS

A number of precedent images on the right illustrate the diverse architectural character of the local buildings, highlighting variations in form and materials.

- Despite variations in design, there is a strong unity among the terrace streets in the area.
- Matching materials, such as gault brick, slate, and red brick decoration, contribute to the cohesive look of the streets.
- In the new buildings, a combination of buff bricks, slate roofs, wooden and metal claddings, and zinc roofs can be observed, particularly in the apartments.
- The residential buildings predominantly feature traditional pitched roofs in terrace arrangements, which lend a sense of regularity and cohesion to the area.
- Stone headers, brick bands, contrast brick details
- The recent buildings exhibit a broader range of roof forms. Some feature single-pitched roofs, while others have roofs with non-symmetrical pitches. Additionally, flat roofs are also prevalent among the structures. This variety in roof designs adds further visual interest and architectural contrast to the area, complementing the overall architectural landscape.



X, NORTH STREET



BENSON STREET



NINE, ST STEPHEN PLACE



LAWRENCE HOUSE



CANTERBURY STREET



48 ALPHA ROAD



WESTFIELD LANE



58 CARLYLE RD, EXTENSION IN THE CONSERVATION AREA



58 CARLYLE RD, EXTENSION IN THE CONSERVATION AREA

2.7 ARCHITECTURAL CONTEXT ANALYSIS

The images below depict the architectural context of Histon Road, showcasing the variety of building typologies in the surrounding area. These include two-storey houses and five-storey office blocks, constructed at different points in time.



1- LANGHAM HOUSE - 3 STOREY



4- LUCY COLLEGE STUDENT ACCOMMODATION - 4 STOREY



7- 62 HISTON ROAD - 2 STOREY



2- LAWRENCE & AKAMAN HOUSE - 4 STOREY



5- BURGESS HOUSE - 3/4 STOREY



8-CHESTNUT HOUSE, STUDENT ACCOMMODATION - 3/4 STOREY



3- RICHARD NEWCOMBE COURT - 3 STOREY



6 - LODGE OF HISTON ROAD CEMETERY - 2 STOREY



9-MOUNT PLEASANT HALLS - 5 STOREY

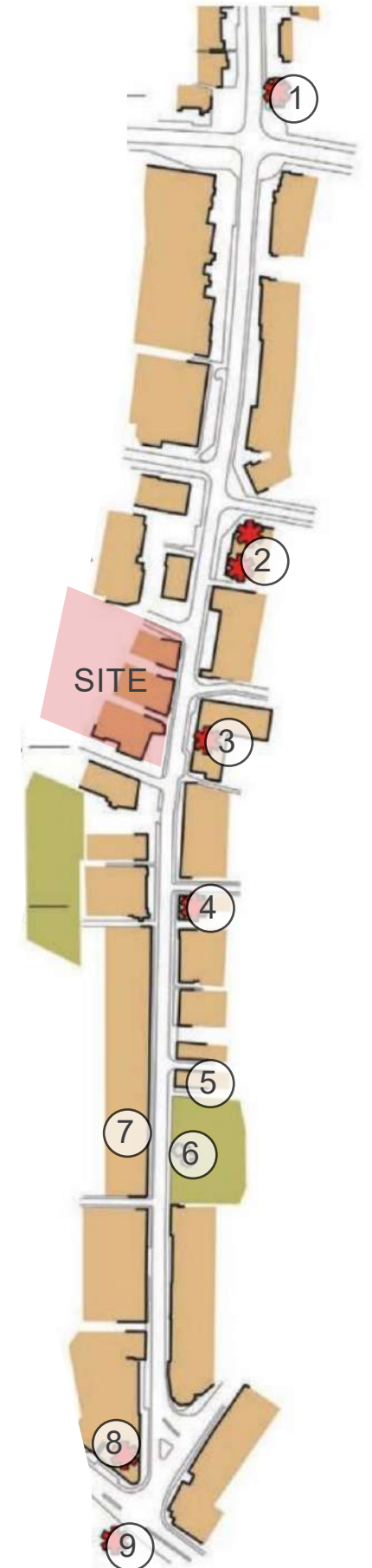

2.8 CONSTRAINTS & OPPORTUNITIES

The site offers many opportunities that help contribute to a successful and desirable place to live. There are, however, constraints on the site which will have an impact on how it can be developed. Key constraints and opportunities relating to the site are listed below:

Constraints

- Boundaries where they are in close proximity to neighbouring buildings.
- Mature trees along various boundaries and how we incorporate these into the design.
- Need to ensure that overshadowing is limited as much as practical
- The southern border adjacent to the park is in poor condition and needs to be reviewed
- multiple site vehicular accesses present and should be reviewed to accommodate safe and practical access
- The existing railings that separate the playground from the rest of the park

Opportunities

- Enhancement of the Histon Road street scene
- Bring the redundant commercial space back into use and provide much needed new homes for Cambridge
- Provide connections to the park enhances its safety and surveillance, while bringing new and existing communities together
- Simplify the existing vehicular access arrangement to reduce conflict points and improve pedestrian environment
- Opportunity to enhance the foot way along Histon Road to provide a more pleasant walking experience
- Opportunity to deliver much needed affordable housing designed to meet the specific needs of local people
- Opportunity to develop a gas-free development and deliver EV connections



KEY:	VEHICULAR ACCESS	CAT A TREES*	SENSITIVE ELEVATIONS	SITE SLOPES DOWN (1.5M CHANGEILE)
VEHICULAR ACCESS TO ATS	CAT B TREES*	CAT C TREES*	INACTIVE ELEVATION	LEVEL DIFFERENCE - 1.5 M
EXISTING CYCLE PATH	CAT U TREES*	RPA - ROOT PROTECTION ZONE	BUILDINGS TO BE DEMOLISHED	PREVAILING WIND
EXISTING PARK FOOT/CYCLE PATH	VIEW TOWARDS PARK	SUB STATION	EXISTING DITCH	SUN PATH
PATHS TO PLAYGROUND	IMPORTANT VIEW**	EXISTING DITCH	NOISE IMPACT	*ALL TREES ARE UNDER TPO
INFORMAL FOOTPATH / TRACK	SENSITIVE ELEVATIONS	CASTLE & VICTORIA RD. CONSERVATION AREA		** IDENTIFIED AT CASTLE AND VICTORIA ROAD CONSERVATION AREA APPRASIAL
RAILING - PLAYGROUND				

3.0 DESIGN DEVELOPMENT

3.1 Design Drivers - 4Cs	18
3.2 Design Concepts	19
3.3 Layout Development	21
3.4 Design Principles	22
3.5 Design Process	23

3.1 DESIGN DRIVERS - 4C



COMMUNITY

- Bring together existing and new communities together at the Histon Road recreation ground.
- Design open spaces that provide a gathering place for its residents, contributing to community cohesion.
- Create a welcoming landscaping scheme to establish an enhanced pedestrian and cyclist journey and a sense of place.



CHARACTER

- Ensure coherent architecture throughout the site that seamlessly integrates with the neighbourhood and aids way-finding.
- Align building form and design with the character of the surrounding area.
- Maintain a harmonious streetscape for buildings facing Histon Road, avoiding excessive visual prominence.
- Utilize landscape elements to create a welcoming and legible neighbourhood.

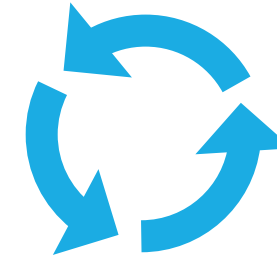

CONNECTION

- Establish physical and visual connections between the Histon Road Recreation Ground to enhance its safety and surveillance while creating scenic and easily accessible routes for new residents.
- Enhance foot way connectivity along the Histon Road front of the site for improved accessibility.
- Prioritize sustainable transportation modes such as walking, cycling, and bus



CLIMATE

- Prioritise sustainable transport alternatives to cars.
- Address overheating, noise, sustainable drainage, and biodiversity.
- Focus on maximizing building performance with low-carbon heating sources.
- Prioritize maximizing building performance through the use of low-carbon heating sources.
- Incorporate electric vehicle charging infrastructure and implement measures to reduce water usage in line with council principles.

3.2 DESIGN CONCEPT

- 137 and 143 Histon Road, once home to the Henison Granaries, played a vital role in the community before closing in 1968. After its closure, the site was transformed into a tire depot. Now, a comprehensive transformation of the site is proposed. This transformation will turn what was a former agricultural and industrial estate into a vibrant and modern residential community that respects the site's rich heritage. The architectural design concept is centred on cultivating a cohesive and modern community seamlessly integrated into the surrounding neighbourhood.
- The proposed buildings draw inspiration from the site's industrial and agricultural heritage. Shallow roofs follow existing industrial roof structures, complemented by large windows and irregularly arranged fenestrations that capture the essence of the site's character. Brick detailing, including ventilation bricks and cladding elements, serves to echo the agricultural nuances intrinsic to the locale, resulting in a uniquely memorable aesthetic.



HISTORIC MAP 1888+1913



HENISON GRANARIES AFTER CLOSURE C.1970



EXISTING BUILD FORMS

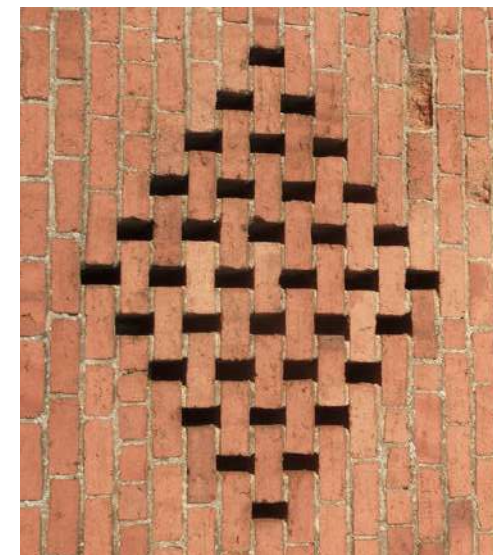

VENTILATION BRICKS



IRREGULARLY ARRANGED FENESTRATIONS

INSPIRATION

Our inspiration draws from the site's history, and our aim is to seamlessly integrate modern living with the charm of the agricultural and industrial heritage of the site. Some key design decisions are listed below:

- Diverse brick colours reflect the palette of farm buildings, creating a vibrant mix.
- Black Brick Detailing is used to mimic ventilation bricks
- Fenestrations are deliberately varied to reflect the typical arrangement seen in granaries
- Large glazings are strategically incorporated on the higher level to authentically mimic the distinctive character of agricultural buildings commonly found in the UK, capturing the essence of their design and contributing to the overall architectural homage to the region's agricultural heritage.
- Modern finishes anchor the design in the present while connecting to the site's history.
- Materials and colours in landscaping aim to create a farmyard atmosphere.
- Street signs and furniture are envisaged to be contemporary in design but reference the industrial and granary heritage

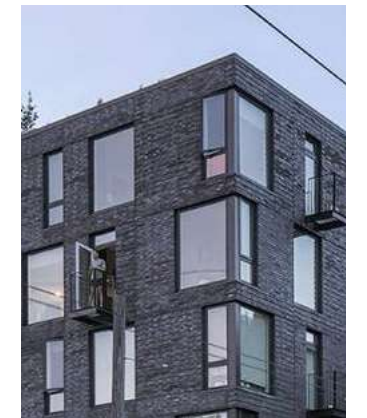
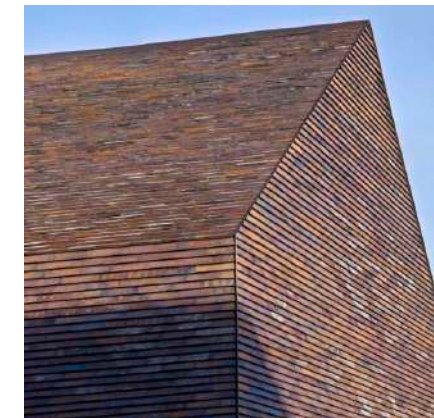

3.3 LAYOUT DEVELOPMENT

1. Evaluate and optimize the existing access for simplified and safe vehicular entry
2. Introduce a buffer zone between existing boundaries and the development. Reduce levels at north west corner to minimise the impact to the adjacent apartments at the north.
3. Extend the character and grain of the conservation area for architectural cohesion
4. Implement a corner apartment building to integrate the new development harmoniously into the existing urban layout
5. Establish visual and physical connections to Histon Road Recreation Ground
6. Enhance Histon Road frontage through landscaping features, incorporating key buildings and vistas for way-finding to create a legible and inviting neighbourhood.

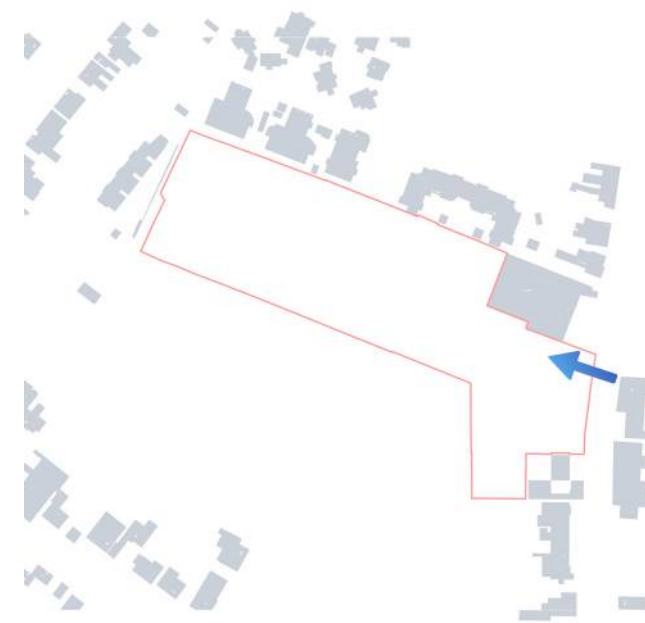

SITE ENTRANCE



ESTABLISHING BUFFER ZONES ADJACENT TO CURRENT PROPERTIES AND REDUCE LEVEL AT THE BUILD-UP AREA

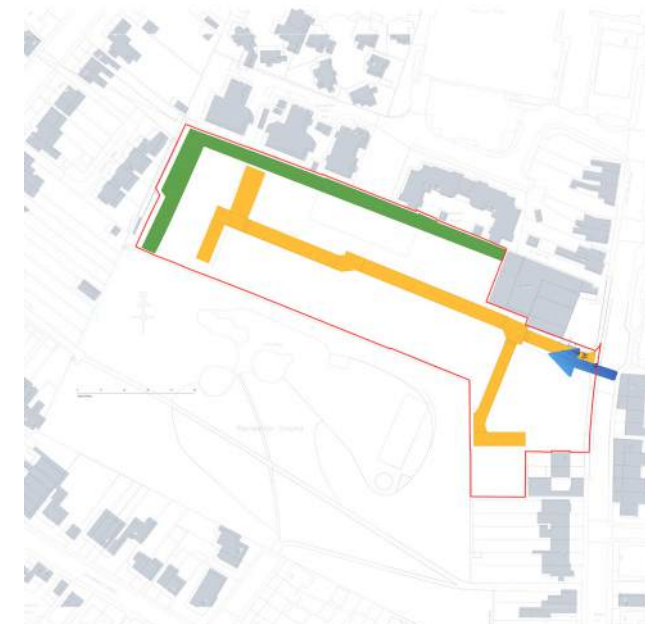

ESTABLISH EFFICIENT ROAD LAYOUT



EXTEND THE CHARACTER AND GRAIN OF THE CONSERVATION AREA

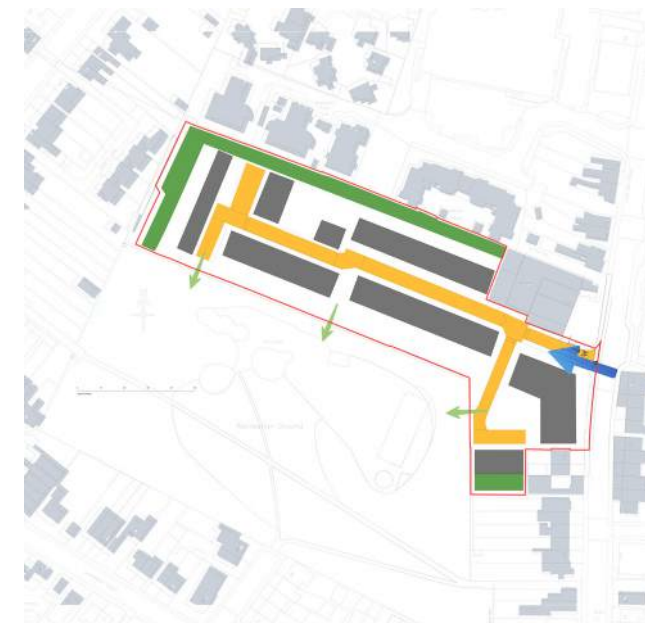

IDENTIFY VISUAL/PHYSICAL CONNECTION POINTS

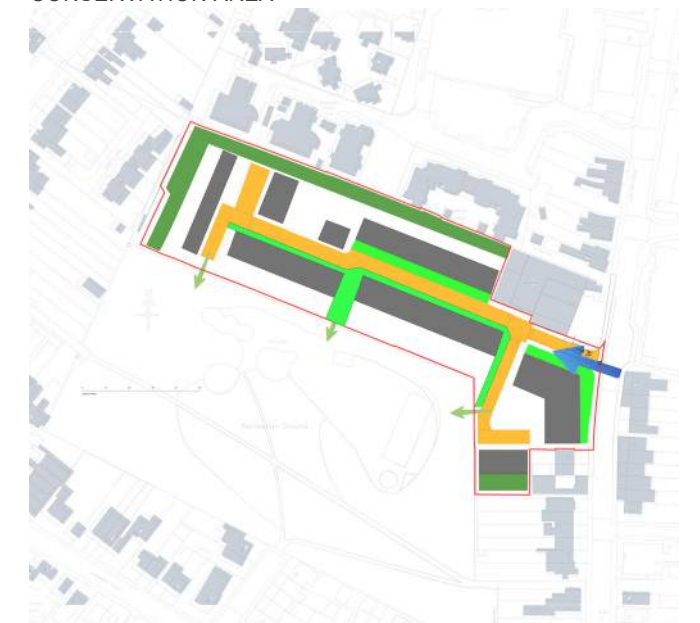

ADD PERMEABILITY THROUGH THE PARK EDGE

3.4 DESIGN PRINCIPLES

- **Integrated Neighbourhood Layout:**

Linear layout aligns with existing architectural characteristics for continuity and integration within the community.

- **Enhanced Histon Road Frontage:**

Widening footway from 1.4m to 2m for improved pedestrian experience.

Introduction of individual doors and landscaping for a safer and inviting environment.

- **Thoughtful Corner-Taking Building:**

Corner-taking building enhances street-scape, seamlessly integrating new development into existing urban layout.

- **Inviting Entrance and Way-finding:**

Welcoming entrance with lush green frontages aids in way-finding and encourages sustainable transport.

- **Permeable Layout:**

Introduction of visual/physical connection to Histon Road Recreation Ground for a permeable and well-connected design.

- **Focal Point at the Yard:**

Vibrant square framed by new and existing residential buildings.

Proposed vista house adds visual interest and serves as a way-finding feature.

- **Consideration of Impact on Existing Dwellings:**

Emphasis on minimizing impact on existing homes with buffer zones between proposed and existing structures.



3.5 DESIGN PROCESS

1. Other options we have tested during the design process



OPTION 1

- The current access arrangement of the ATS workshop legally has to remain as it is proposed due to ATS's retained ownership of the working garage.
- The total number of homes would be 63 for this option, reflecting a decrease of 8 homes.
- 3 affordable homes would be lost in this option.

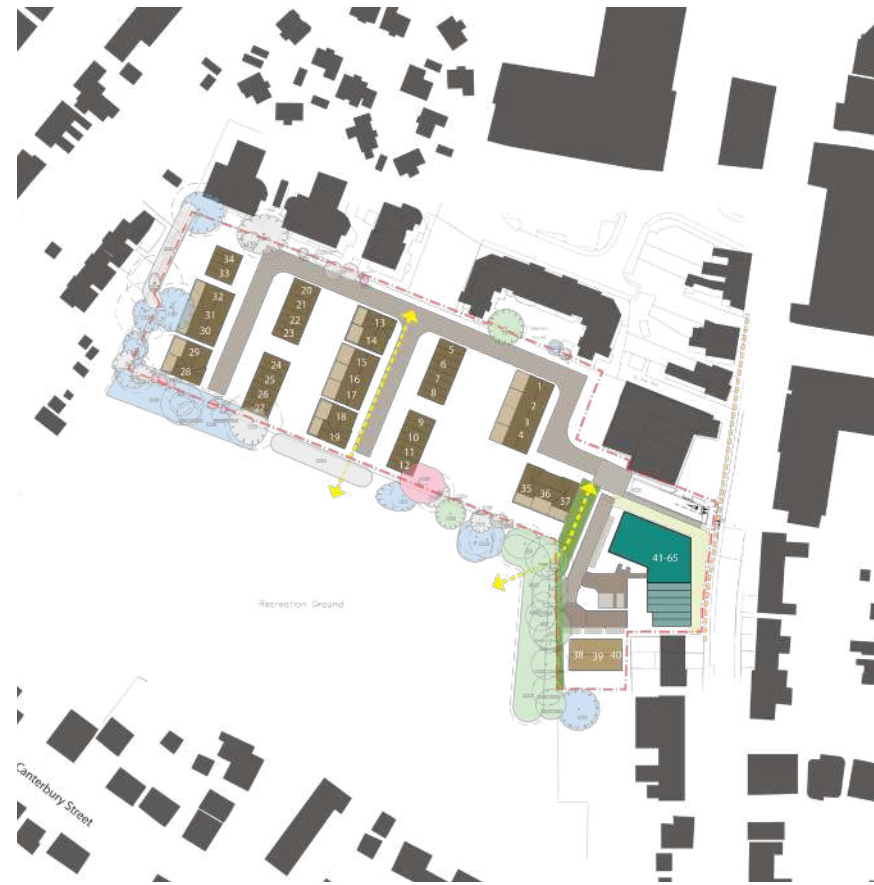

OPTION 2

- This option would result in 65 homes in total, reflecting a decrease of 6 homes.
- 2 affordable homes would be lost in this option.
- Refuse vehicle turning is not possible.
- Cul-de-sacs are over 45m; a bin collection point is required.
- A vista house is required at the end of the main road; however, it is not possible due to restrictions imposed by existing buildings and trees.



OPTION 3

- The linear layout (plots 1-14) might cause an unattractive street scene.
- rear gardens of plot 15 to 18 overlooked by existing apartments.
- The vista view from the green link towards the north is dominated by cars.

4.0 THE PROPOSAL

4.1 Proposed Layout	25
4.2 Movement & Connectivity	26
4.3 Sustainability Principles	27

4.1 PROPOSED LAYOUT - SUMMARY



Schedule of Accommodation

	TYPE	TOTAL	%
AFFORDABLE	1 BEDROOM	15	54%
	2 BEDROOM	9	32%
	3 BEDROOM	4	14%
	TOTAL	28	
PRIVATE	2 BEDROOM	7	17%
	3 BEDROOM	21	50%
	4 BEDROOM	14	33%
	TOTAL	42	

Housing Diversity:

- 70 homes, ranging from family homes to apartments
- 40% (28 homes) designated as council rented affordable homes

High-quality landscape design:

- The proposed layout includes the addition of 32 new trees within the application site, as well as the planting of an additional 23 trees within the park area, aiming to improve both aesthetics and biodiversity.

Emphasis on visual and physical connectivity to Histon Road Recreation Ground

Incorporation of sustainable urban drainage features

Mindful approach to sustainability

Cycle-friendly infrastructure:

- Provision of 180 secure cycle spaces provided at the front and rear garden
- 36 secure cycle spaces provided for apartments
- Additional 4 visitor cycle spaces

Car parking provision:

- 53 total parking spaces
- 45 spaces allocated for 2, 3, and 4-bedroom homes
- 2 accessible parking spaces designated for M4(3) flats apartments, including
- 6 visitor parking spaces
- Discussions are being held with the Council's park and recreation team to work up an indicative layout for the recreation ground to enable secure connections and enhancements. The full detail of the recreation ground works are expected to be secured by condition / under the s106 in a similar process typical for public open space delivery

4.2 MOVEMENT & CONNECTIVITY

- Our objective is to create a site that encourages sustainable modes of travel and enhances existing connectivity for both current and future residents. To achieve this, we have examined the current movements of cyclists and pedestrians around the site.
- There are cycle lanes and foot ways on Histon Road, linking to the city centre in the south and Arbury in the north. Additionally, there is a cycleway along the south of Histon Road Park, connecting Richmond and Histon Road, with a connection from Canterbury Street.
- The main access points to the park are from Richmond Road, Canterbury Road, and Histon Road. Histon Road access is approximately 400 meters away from the farthest point of the site.
- We looked at different ways to connect the site to the park. After considering everything, we found that Connections A and B are the most suitable without disturbing the play area and existing trees, considering the existing topography of the site.
- Link A is the main access point, and B is a secondary access.
- Both proposed accesses are pedestrian-only.
- Link A provides dog-free entry to the existing play area through a gate similar to the one on the opposite side of the play area.
- Link B can be arranged as pedestrian-only without restrictions if the railing arrangement can be rearranged in this part of the park.

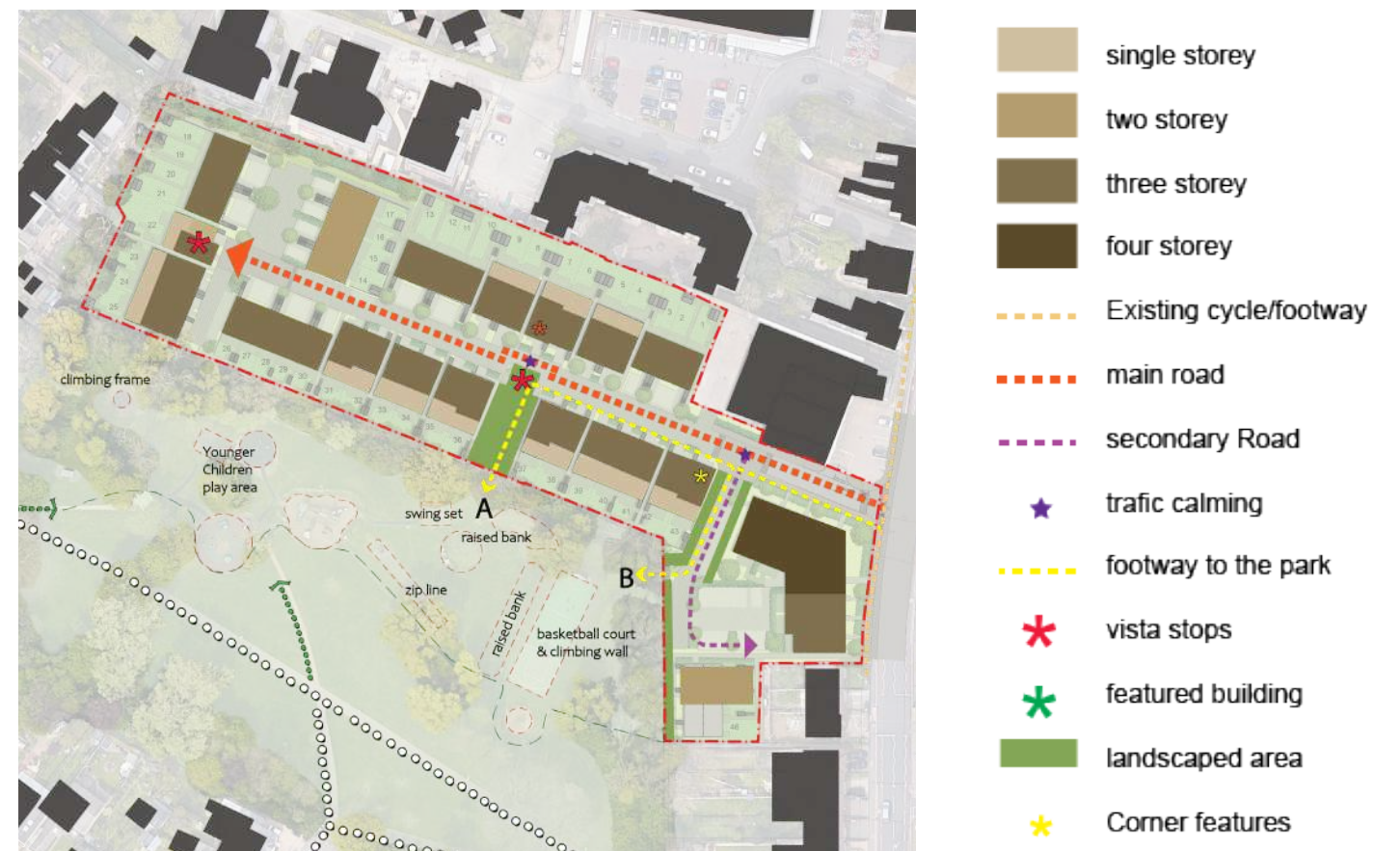

4.3 SUSTAINABILITY PRINCIPLES

Sustainability encompasses a number of different elements and has comprised a core component of the development from its inception.

Building Performance:

- The development will be entirely gas-free, employing air source heat pumps.
- All homes will adhere to enhanced fabric standards, The Hill ESG 2030 roadmap (attached) is targeting a 10% reduction in embodied kgCO₂e/m² from 2025, 20%:2028 & 40%:2030 in readiness for FHS and a future Part Z.

Overheating:

- Sustainability consultants are evaluating the development's overheating performance, conducting tests in accordance with new Part O and TM59 regulations, with their report included in this application.

Promoting Sustainable Travel:

- Encouraging walking and cycling as primary modes of travel.
- Cycle storage will be located in positions which are more convenient than access to the car
- All new homes, both private and affordable, will have an access to electric vehicle charging points.

Biodiversity:

- The Landscape Architect collaborates with the Ecological consultant to maximize on-site biodiversity through thoughtful design and planting selection.

Water Conservation:

- A water conservation strategy commits to a dwelling water use of no more than 99 litres/ person/day, surpassing Cambridge Local Plan policy. Further review is underway to potentially reduce usage in alignment with the LPA's goals of decreasing water consumption.



5.0 ARCHITECTURE DEVELOPMENT

5.1 Build form & Features	29
5.2 Materials & Precedents	30
5.3 Design Developments - Apartment	3





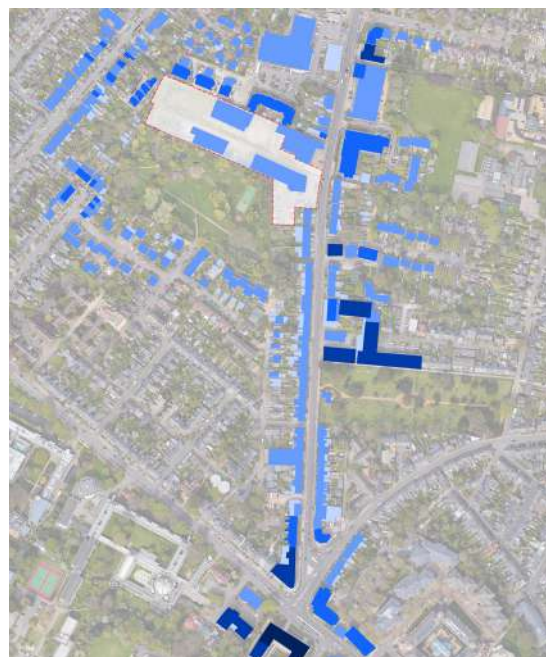





5.1 BUILD FORM & FEATURES

- The proposed architectural forms draw inspiration from the surrounding site context. The apartment building situated at the Histon Road corner, seamlessly integrates our new development with Histon Road.
- Along the primary routes, the buildings are designed as 3-storey structures, reflecting the character of town houses. The build line, however, is artfully varied to create an engaging street scene. Towards the west, the proposed homes frame the yard.
- Architectural detailing is carefully crafted to maintain a cohesive aesthetic throughout the site. Primary and secondary elevations are differentiated with brick detailing and materials, yet they share common forms and fenestrations.
- The material palette is thoughtfully chosen to distinguish character areas while preserving an overall harmonious architectural ambiance. Special attention has been given to identified vista points, with unique elevational considerations for these buildings. Notably, special features have been incorporated into visible side elevations to activate these aspects.
- Landscape features are meticulously planned, utilizing traffic calming measures as additional visual points of interest.



BUILDING HEIGHTS - STOREY



- | | | | |
|---|----------------------|---|------------------------|
|  | single storey |  | primary frontage |
|  | two storey |  | secondary frontage |
|  | three storey |  | active side elevations |
|  | four storey |  | vista stops |
|  | five storey |  | featured building |
|  | histon road frontage | | |

5.2 MATERIALS & PRECEDENTS



REGULAR ROOF FORMS - INDUSTRIAL REF.



ROOF TILES ARE USED ON THE FACADE OF THE VISTA HOUSE.



BLACK CLADDING DETAILS

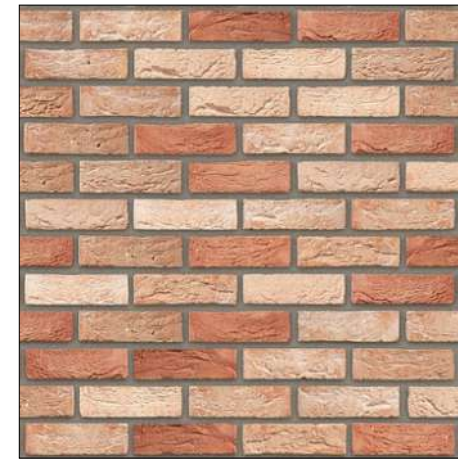

RED BRICK MIX



GREY/BLACK/WHITE MIX



RED TILES



DARK ROOF TILES



EXTRUDED BLACK BRICK DETAILS



INFORMAL FENESTRATION ARRANGEMENTS



BIKE SHEDS - FRONT

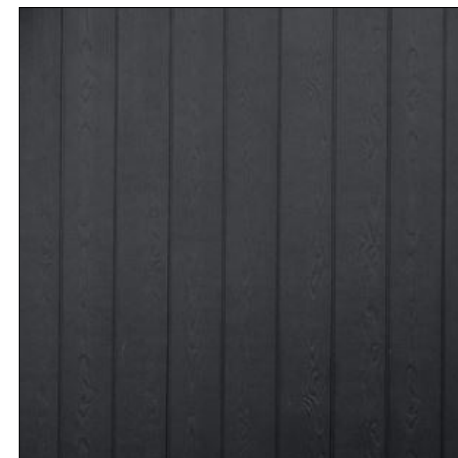

CLADDING

UPDATE THIS ACCORDINGLY WITH OUR NEW DESIGN



SIGNAGE REFLECTING SITE CONTEXT



DARK COLOURED GUTTER & DOWN PIPES

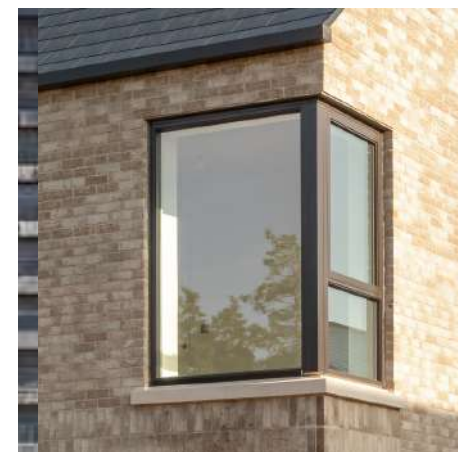

CORNER WINDOWS AT IMPORTANT CORNERS



COMPOSITE / METAL WINDOWS

5.3 DESIGN DEVELOPMENTS - APARTMENT



A proposed four-story mass for an apartment building located at the site's corner.



A pitched roof was added to further reduce the overall mass. The three-story section of the apartment also functions as a transitional element between the existing houses and the four-story part of the apartment building. The selection of roof types not only pays homage to the industrial heritage of the site but also provides insight into the architectural style of the proposed houses.



The height of the building was reduced next to the existing houses along Histon Road



Cycle storage has been positioned at the building's corner to provide easy access for cyclists. The ancillary element of the apartment provides flexibility in fenestration arrangement, allowing for the reflection of characteristic features found

MEMBERS' BRIEFING



Entrance doors for ground floor flats added to enhance the street scene

An enlarged opening is proposed for the communal entrance to create a more legible building. Larger openings are also a common feature in granary buildings.



Balconies have been added where necessary and grouped. This not only creates high-level voids to break the brick mass but also help us to create a playful elevation.



To start, all windows are arranged in a regular pattern.



To enhance visual interest, we manipulate the openings to break the monotony of the elevations. Fenestrations are used as a tool to create an animated and dynamic facade.

MEMBERS' BRIEFING



Black brick headers are used to form a ventilation brick pattern and strategically placed within the elevation. This not only allows us to echo granary features but also introduces an interesting detail that enhances the charm of these corner buildings.

Ventilation details are incorporated at the corner where the cycle storage is placed, providing natural ventilation and adding interest to the building.



The proposed landscaping will enhance the setting of the building as well as the Histon Road street scene.

6.0 LANDSCAPE DESIGN

6.0 Landscape

6.1 Design Concept	35
6.2 Concept Design - Development Area	36
6.3 Landscape Proposals - Development Area	37
6.4 Tree planting - Development Area	38
6.5 Hard landscape - Development Area	39
6.6 Concept Design - Recreation Ground (North)	40
6.7 Concept Design - Recreation Ground (South)	41
6.8 Landscape proposals - Recreation Ground	42

6.1 DESIGN CONCEPT



6.2 CONCEPT DESIGN - DEVELOPMENT AREA

Industrial Heritage

Distinctive and contrasting character between the site's former heritage urban/industrial use and its neighbouring green park/recreation ground.

Henison Granaries was a hard landscape with large, shed buildings and cobbled yards. There would have been very little green and planting would have been limited and restricted to the boundaries only.

Existing tree planting within the site would have been self-seeded and relatively young, post dating the granary.

The landscape within the development draws its inspiration from the granary and the proposed architecture with a simple cobbled palette of surfacing materials. The shared surface approach minimises clutter and reflects the yard treatment. The cobbles and blocks harmonise with the colours and textures of the architectural façades with a mix of red, buff and grey.



HENISON GRANARIES
AFTER CLOSURE C.1970



EXISTING ENVIRONMENT - HARD STANDING DOMINANT, TREES MAINLY ON BOUNDARY
WITH YOUNG SELF-SEEDED TREES WITHIN SITE

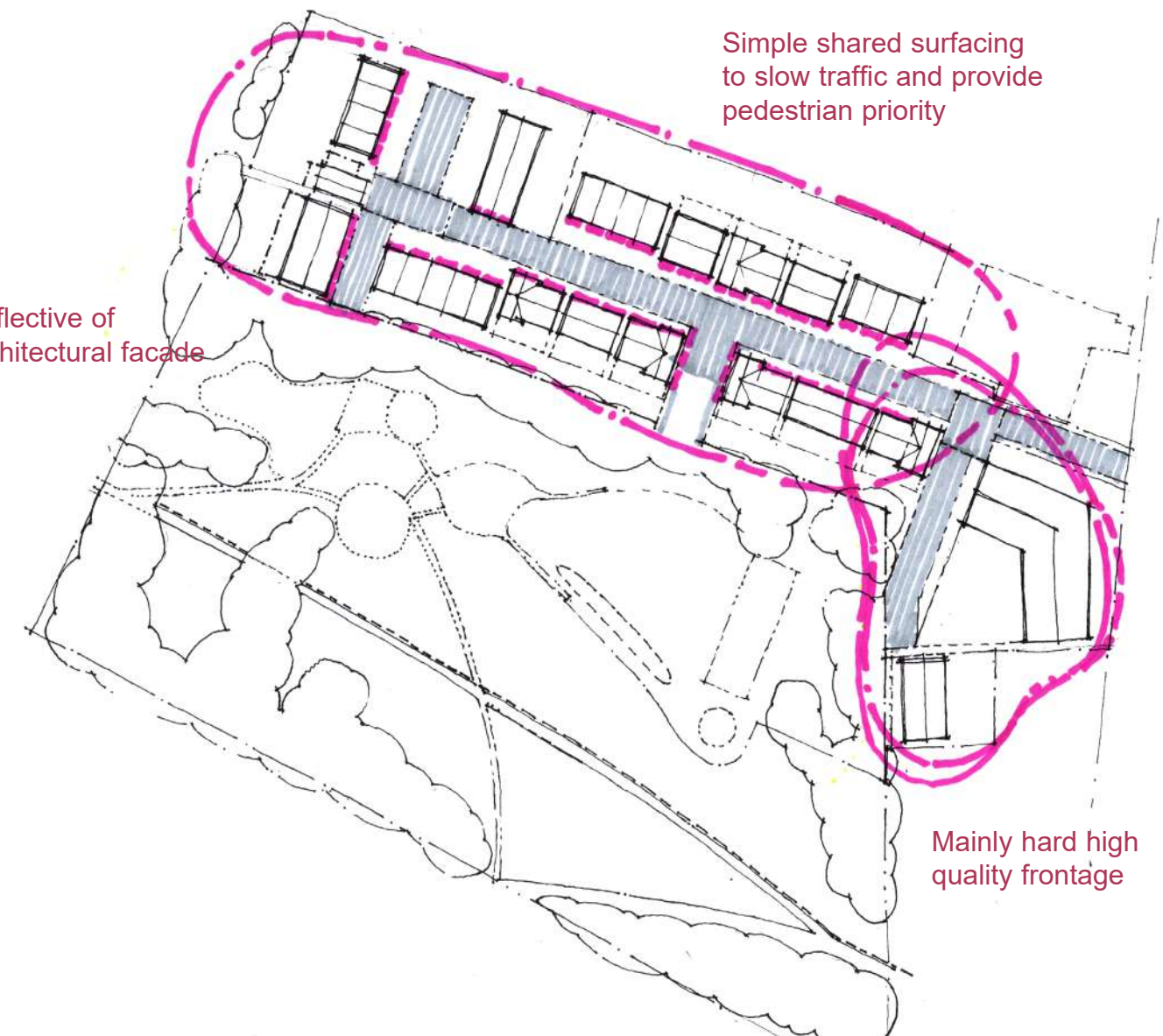

THE GRANARY, LEEDS, COAL DROPS YARD, LONDON AND THE GRANARY, BARKING.

- Cobbled surfacing, no need for embellishment.
- Robust and industrial materials - metal, with some timber to create warmth.
- A simple and honest landscape to match the architecture.



6.3 LANDSCAPE PROPOSALS - DEVELOPMENT AREA

1. Histon Road frontage – A robust evergreen hedge and street trees provide a green façade to the development improving the Histon road street scene adjacent to the site.
2. A green-fronted arrival space welcomes people into the development. The main spine road there will be hedge planting on one side and an avenue of street trees under-planted with ornamental shrubs on the other.
3. The end of the spine road the space widens to the north to form a yard character areas. This is enclosed by tree and mixed ornamental planting with informal seating to encourage residents to interact.
4. Key boundaries are treated with native hedgerow planting to encourage wildlife, to enhance biodiversity and provide enclosure. Located next to existing vegetation to help connect the site to recreation ground existing vegetation.
5. A central green link and south-eastern path provide two connections into the recreation ground. The links encourage residents to utilise the recreation ground amenity. The links also potentially provide a quicker route to Histon Road for park users.

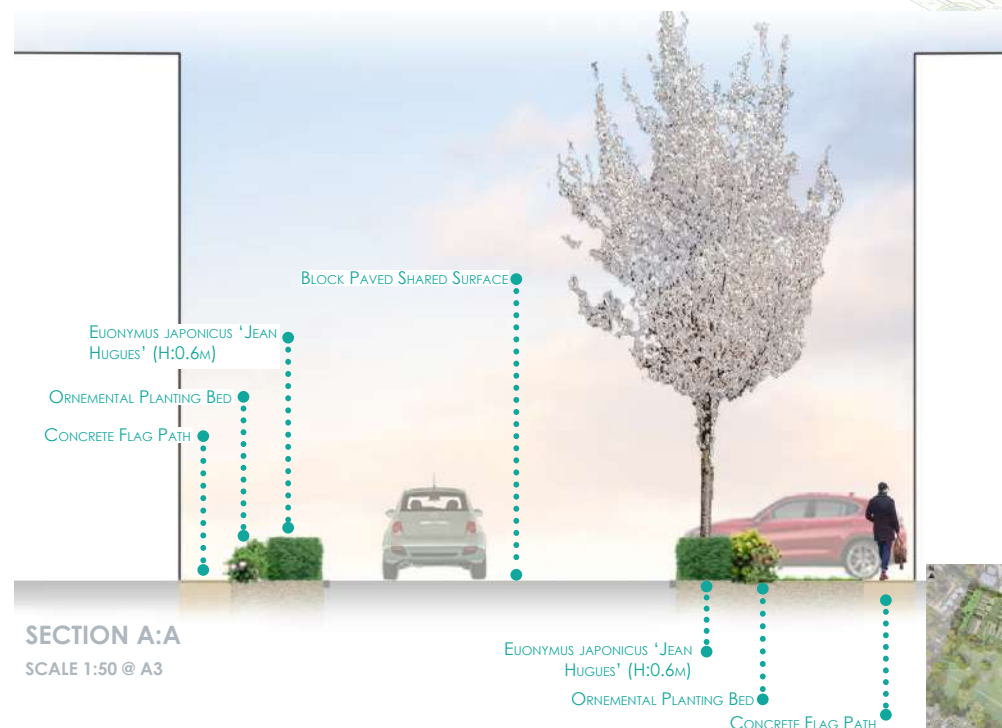
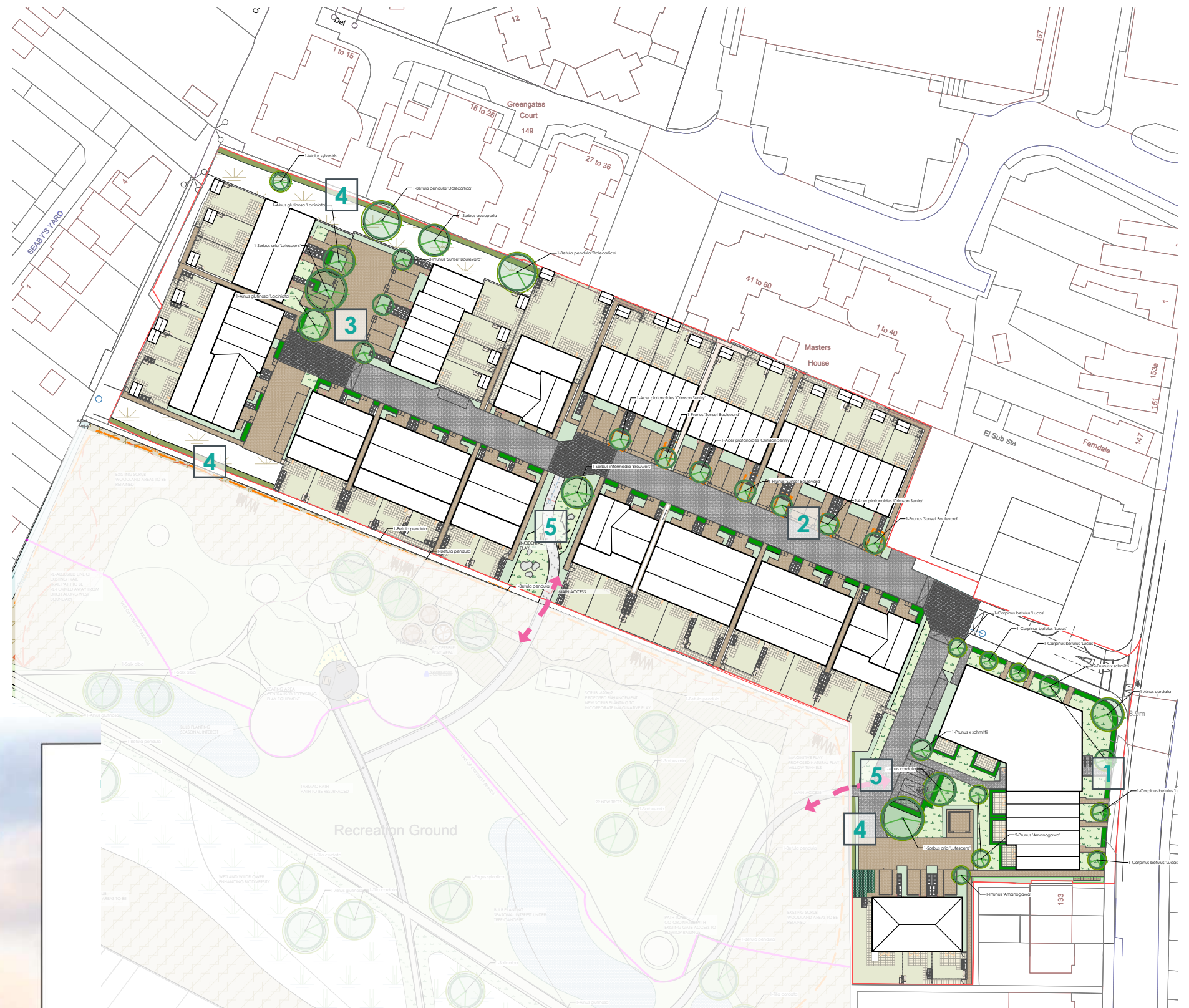



Hedges and tree-lined main spine road

6.4 TREE PLANTING - DEVELOPMENT AREA

Planting

KEY

-  Skyline trees
-  Large trees
-  Native trees
-  Street trees
-  Ornamental trees
-  Drainage/Attenuation Crates



SORBUS ARIA 'LUTESCENS'



ALNUS INCANA 'LACINIATA'



ALNUS CORDATA









BETULA PENDULA 'DALECARLICA'

1. Street / Feature Trees to enhance frontage along Histon Road
2. Line of trees along entrance driveway to provide a green outlook from Histon Road and to soften the street scene.
3. Large tree at entrance to green link to further green the street and provide a feature at the intersection of the street and entrance to the recreation ground.
4. Tree and shrub planting at end of view to soften the gable end/house frontage and to provide a feature.
5. Trees within the yard area to soften space and provide shade.
6. Native tree hedge along northern boundary to form a screen and green backdrop. To be maintained by a management company (outside of private ownership).
7. Amenity space to the rear of apartments affords room for Skyline Tree.

6.5 HARD LANDSCAPE - DEVELOPMENT AREA

KEY

-  Permeable Blockpaved
-  Raised tables ramps
-  Raised tables/level access
-  Tarmac Surface
-  Indicative location lighting
-  Indicative location of signage
-  Indicative location of benches



EXAMPLE OF COBBLE/BLOCK PAVED SHARED SURFACE



EXAMPLE OF TIMBER AND CORTEN MATERIALS

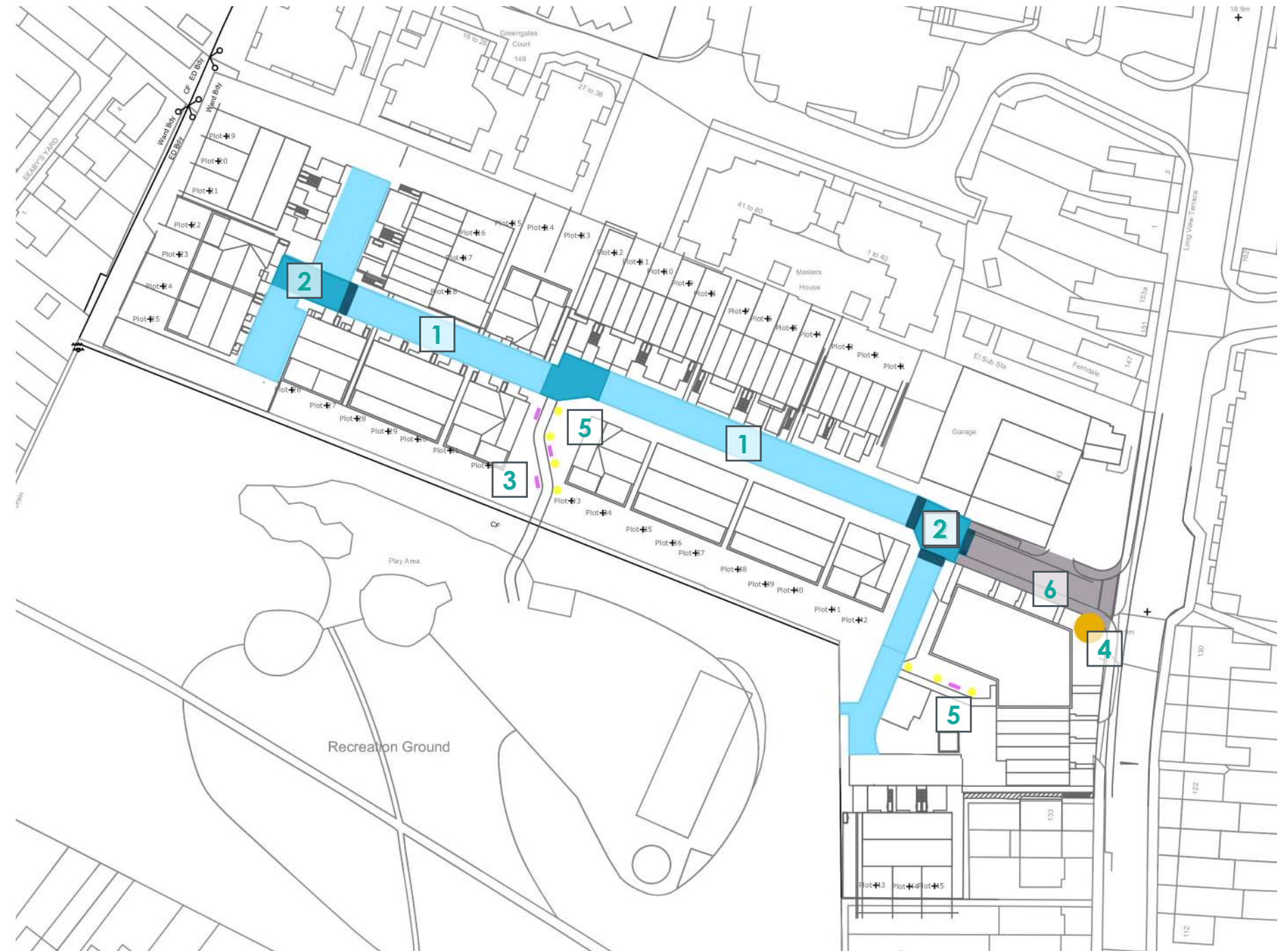

1. Shared surface to be block paving. Simple approach with minimal markings.
2. Raised tables with contrasting block paved top. To further demarcate pedestrian dominance at the entrance to the green link and courtyard areas.
3. Seating positioned throughout the development, with corten steel base and timber slat top.
4. Corten steel signage to act as welcome into the development and providing orientation throughout and into the recreation ground.
5. Lighting and bollards to be corten steel. All lighting to be designed to minimise disturbance to bats, especially at the southern side of the site at the entrance into the recreation ground.
6. Tarmac surfacing to both road and pavements at entrance way from Histon Road

6.6 CONCEPT DESIGN - RECREATION GROUND (NORTH)

Transition and Play

The recreation ground is a treasured and valuable local resource, providing green space for all and opportunities for play for children.

The enclosed tree line along the northern boundary offers a place for children to run and hide and play within a natural environment. This could be enhanced through the addition of new and natural elements which further promotes imaginative play. This contrasts with the more open and safe play equipment further to the south.

More seating and tables could also be provided in the centre of the recreation ground to provide a comforting environment for parents and adult carers to sit and gather.

Small play items could also be located within the development as gateway features which lead into the recreation ground.



EXISTING PLAY - FORMAL, SAFE PLAY IN OPEN SPACE AND ADVENTUROUS, ENCLOSE PLAY WITHIN NORTHERN BOUNDARY TREE BELT

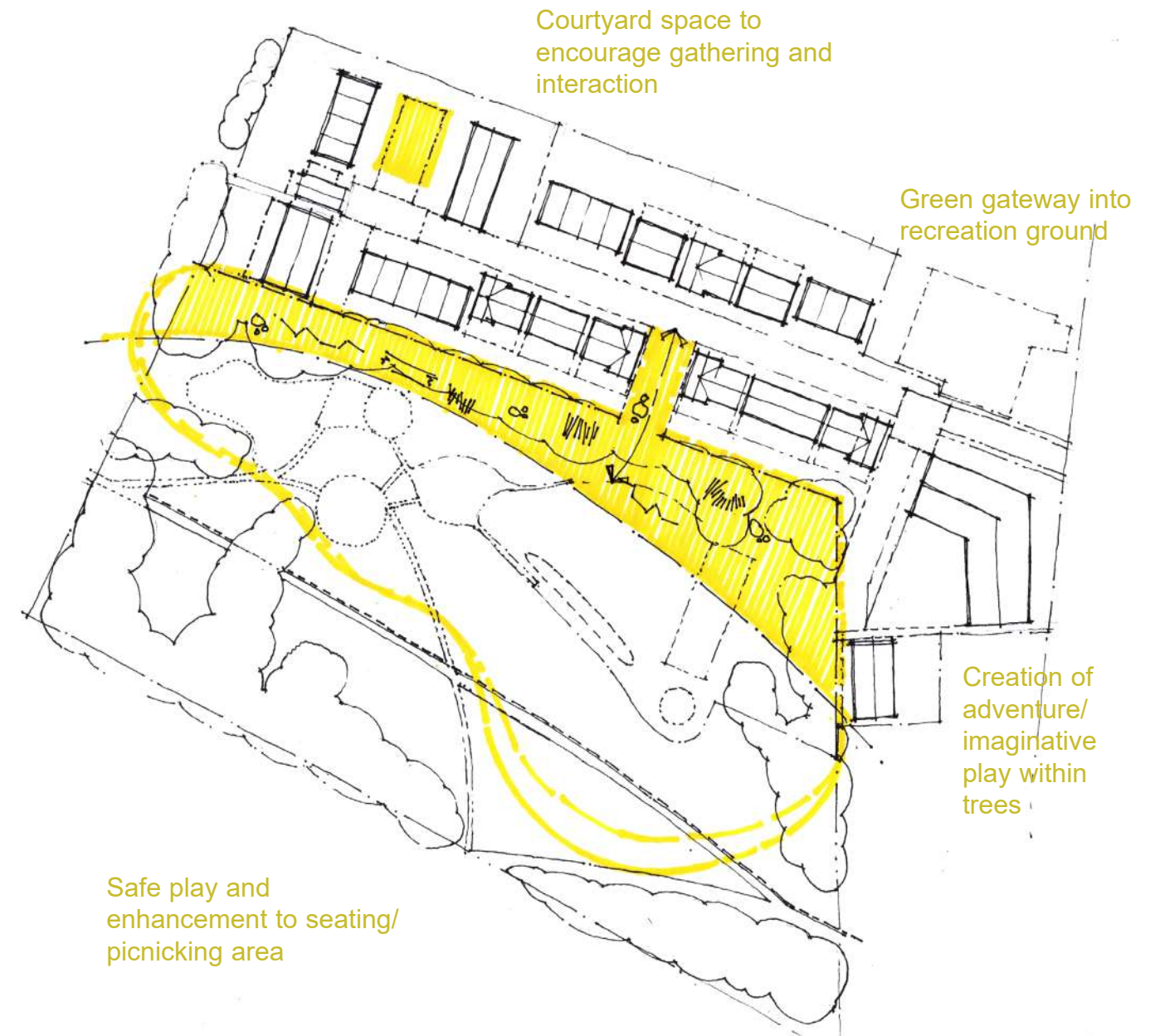

EXAMPLE WOODLAND PLAY WITH SCULPTURAL TEEPEE FEATURES, WILLOW TUNNEL AND TABLES AND SEATING FOR GATHERING PARENTS

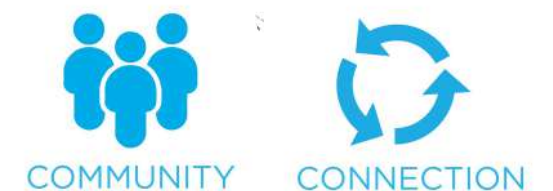

6.7 CONCEPT DESIGN - RECREATION GROUND (SOUTH)

Parkland and Nature

The recreation ground provides a green and natural retreat close to the centre of the city and a haven for nature.

The ecology could be enhanced to increase the biodiversity value and it is expected that the management of these areas would be documented to ensure establishment and success. The ecologist would be consulted to achieve appropriate and maximum gain.

Environmental interpretation could also be incorporated into the scheme in the form of sculpture and/or panels to describe the ecological value of our urban open spaces.

Ecologically rich planting would also permeate through the development into the gateway green areas and the planting beds to house frontages and along the site's boundaries where further ecological corridors could be enhanced.



EXISTING TREES ALONG NORTHERN BOUNDARY AND GRASS AREA WITHIN RECREATION GROUND

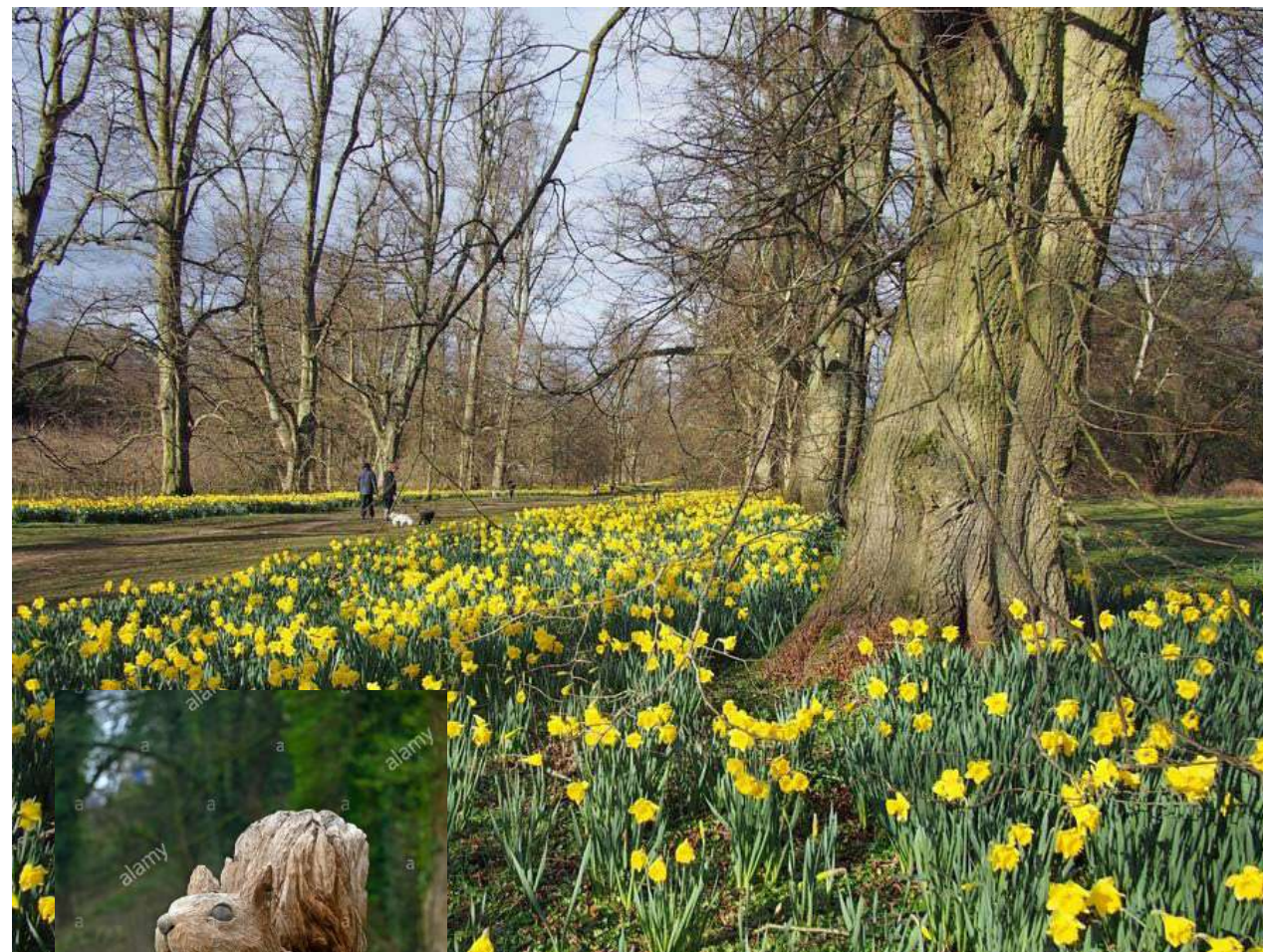

EXAMPLE OF BULB PLANTING AND NATURE INTERPRETATION/SCULPTURE

- Provide ecological enhancements within recreation ground.
- Environmental interpretation/sculpture to provide environmental narrative.
- Green interventions within the development to soften the hard environment.



6.8 LANDSCAPE PROPOSALS - RECREATION GROUND



1. Two new access points into the recreation ground to increase permeability and new/improved links.
2. Extension of planted area with trees and shrubs to provide an adventure play space for disability access, i.e. smooth surface path to play features such as Teepee's.
3. Smaller woodland play features such as willow tunnels within woodland clearings.
4. New native tree planting whilst still maintaining open spaces and sunny aspect in centre of recreation ground.
5. Provide mulch surface to enhance existing woodland trails around perimeter of the recreation ground.
6. Create central gathering space for parents and carers.
7. Introduction of native bulb swathes to create seasonal interest and enhance ecological value.

7.0 STRATEGIES

7.1 Parking	44
7.2 Refuse	46
7.3 Housing Typology	47
7.4 Tenure	48
7.5 Building Relations	54
7.6 Street & 3D views	57
7.7 Trees	60
7.8 Drainage	61

7.1 PARKING

The proposed layout aims to encourage cycling as preferred modal choice over using the car. To achieve this, we have and additional cycle storage is also provided within their gardens. The apartments benefit from easily accessible enclosed cycle storage on the ground floor, designed in accordance with the criteria outlined in the 'Cambridge City Council Cycle Parking Guide for New Residential Developments.'

The allocation of cycle parking spaces adheres to the following standards:

One space per bedroom for dwellings with up to three bedrooms.

Three spaces for four-bedroom dwellings.

In cases where cycle storage is split between the front and rear, these houses benefit from additional cycle storage. This hybrid cycle storage proposal enables flexibility so occupants can decide whether to store cycles at the front or rear of the property depending on their preferences and in a way which is both easily accessible and secure'

Each house is allocated one car parking space, and for flats, 2 accessible parking spaces per accessible flat will be provided. In total, there are 47 parking spaces provided for the whole area. Additionally, there are 6 visitor parking spaces, which are evenly spread out for guests and visitors. Overall, the site benefits from an average of 0.67 car parking spaces.

All parking spaces are 2.5m by 4.8m and has additional 0.9m hard surface also provided for houses to compliant with M4(2) requirements. All garages are at least 3.3m by 6m.



Dwelling size	Inside controlled parking zone	Outside controlled parking zone
Up to 2 bedrooms	No more than 1 space per dwelling	No more than a mean of 1.5 spaces per dwelling
3 or more bedrooms	No more than 1 space per dwelling	No less than a mean of 0.5 spaces per dwelling, up to a maximum of 2 spaces per dwelling

CAMBRIDGE PARKING STANDARDS - LOCAL PLAN 2018 - PAGE 408



CYCLE STORAGE - UP TO 3 BIKES



CYCLE STORAGE - UP TO 3 BIKES



CYCLE STORE - APARTMENT ARRANGEMENT

EXAMPLE FRONT OF PROPERTY CYCLE STORE TO ACCOMMODATE UP TO THREE CYCLES

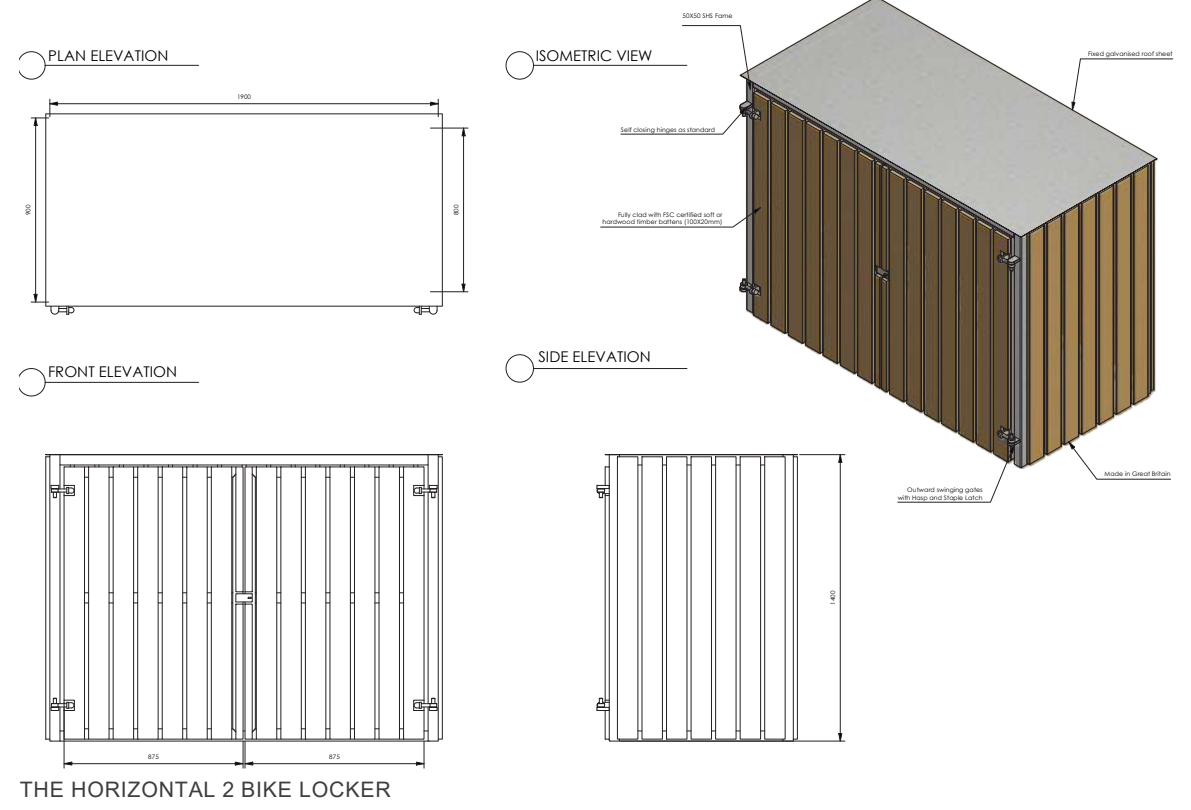

THE HORIZONTAL 2 BIKE LOCKER

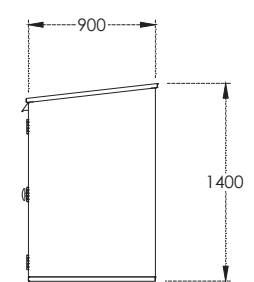
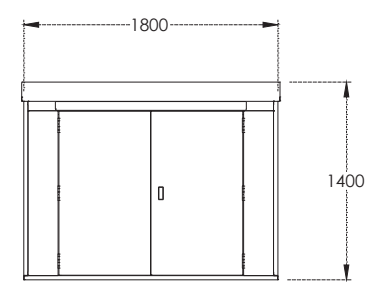
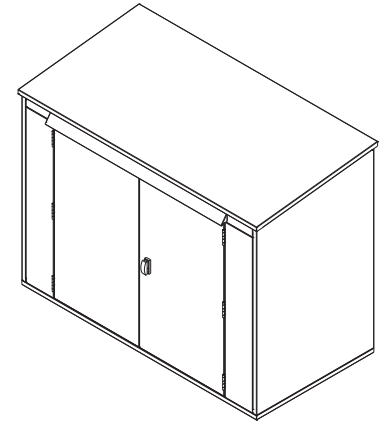
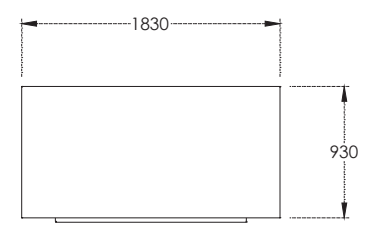

THE HORIZONTAL 3 BIKE LOCKER

7.2 REFUSE

Our waste management approach adheres to the Waste Storage & Collection guidelines outlined by the Cambridge City Council for developers. Residential bins will be collected from the kerbside, except for plots 43-45, which have a designated collection point along Histon Road. This arrangement aims to reduce the number of turns required for the refuse vehicle.

For apartments, bin storage is situated on the ground floor, aligning with the council's guidance.

The road infrastructure has been designed to meet the council's standards, ensuring it can withstand the weight of the 32-tonne refuse vehicle

- Bin Collection Point
- Bin Storage - Houses
- Kerb-side Collection - Houses
- Apartments Bin Collection Route
- Existing Refuse Vehicle Route
- Proposed Refuse Vehicle Route
- Refuse Vehicle Reversing
- Refuse Vehicle Turning



7.3 HOUSING TYPOLOGIES

Proposed site layout provides 45 houses and 25 flats. The breakdown of these homes is as follows:

Mix

- 1 Bedroom - 15 Homes - 21
- 2 bedroom - 13 Homes - 23
- 3 Bedroom - 30 Homes - 36
- 4 bedroom - 13 Homes - 20

Total : 70 Homes

PRIVATE - 42 UNITS - 60%

- 2 BED, 4 PERSON HOUSE X 7
- 3 BED, 6 PERSON HOUSE V1 - 12
- 3 BED, 6 PERSON HOUSE V2 - 8
- 3 BED, 6 PERSON HOUSE V3 - 1
- 4 BED, 7 PERSON HOUSE - 13
- 4 BED, 8 PERSON HOUSE - 1

AFFORDABLE - 28 UNITS - 40%

- APARTMENT BLOCK - 25
- 1 BED, 2 PERSON FLAT - 15
- 2 BED, 4 PERSON FLAT - 8
- 2 BED, 3 PERSON FLAT (WCH) - 1
- 3 BED, 5 PERSON FLAT (WCH) - 1
- 3 BED, 5 PERSON HOUSE - 3



THE SITE CONSISTS OF 68 M4(2) HOMES AND 2 M4(3) FLAT, AS REQUIRED BY THE COUNCIL'S PLANNING POLICY







7.4 HOUSING TENURE

The proposed site layout delivers 40% affordable and 60% private homes. The breakdown for the affordable homes is listed below:

Affordable - 28 units - 40%

UNIT TYPE	NUMBER OF UNITS	PERCENTAGE
1 BED, 2 PERSON FLAT	15 UNITS	54%
2 BED, 4 PERSON FLAT INCLUDES ONE 2 BED, M4(3) FLAT	9 UNITS	32%
3 BED, M4(3) FLAT	1 UNIT	14%
3 BED, 5 PERSON HOUSE	3 UNITS	

- All homes design to be tenure blind
- The location of homes is chosen strategically to maximize the benefits of the park and reduce management costs for both the council and residents.
- Location of the apartment block determined during the early design stage, we explored various alternative locations for the apartment block. Ultimately, positioning the apartment block at the corner is the best choice to contribute to a more cohesive and harmonious street-scape. This approach allows us to create a communal green frontage along Histon Road, which will be overseen and maintained by a professional management company. This ensures that the quality and sustainability of the proposed landscape will be maintained.

	AFFORDABLE - EXISTING		PRIVATE - 43 UNITS
	STUDENT ACCOMMODATION		AFFORDABLE - 28 UNITS
	ASSISTANT LIVING		PRIVATE - EXISTING

THE SITE CONSISTS OF 70 M4(2) HOMES AND 2 M4(3) FLAT, AS REQUIRED BY THE COUNCIL'S PLANNING POLICY



AFFORDABLE APARTMENT FLOOR PLANS & TYPICAL ARRANGEMENT

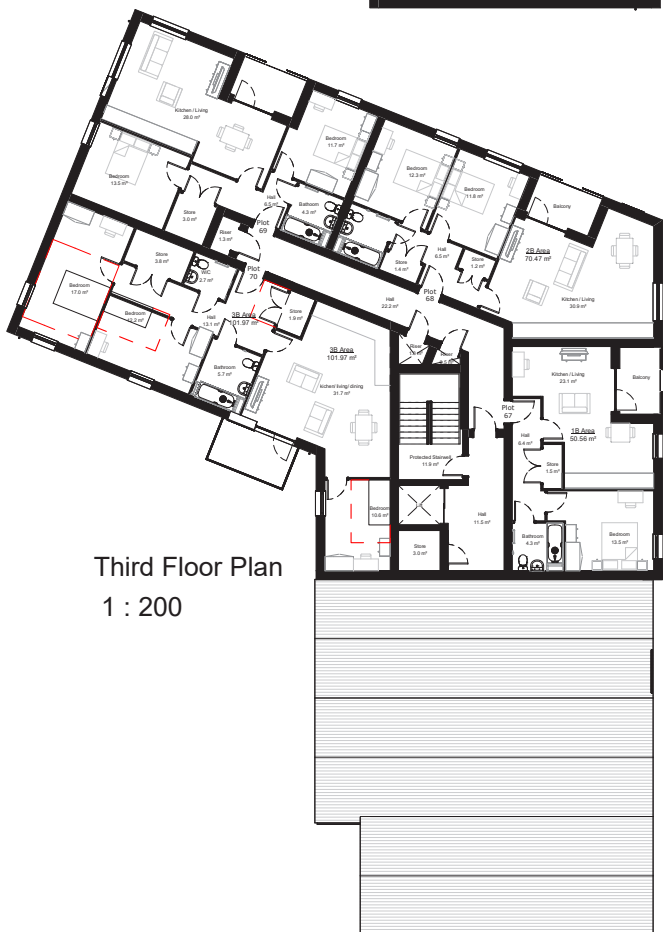
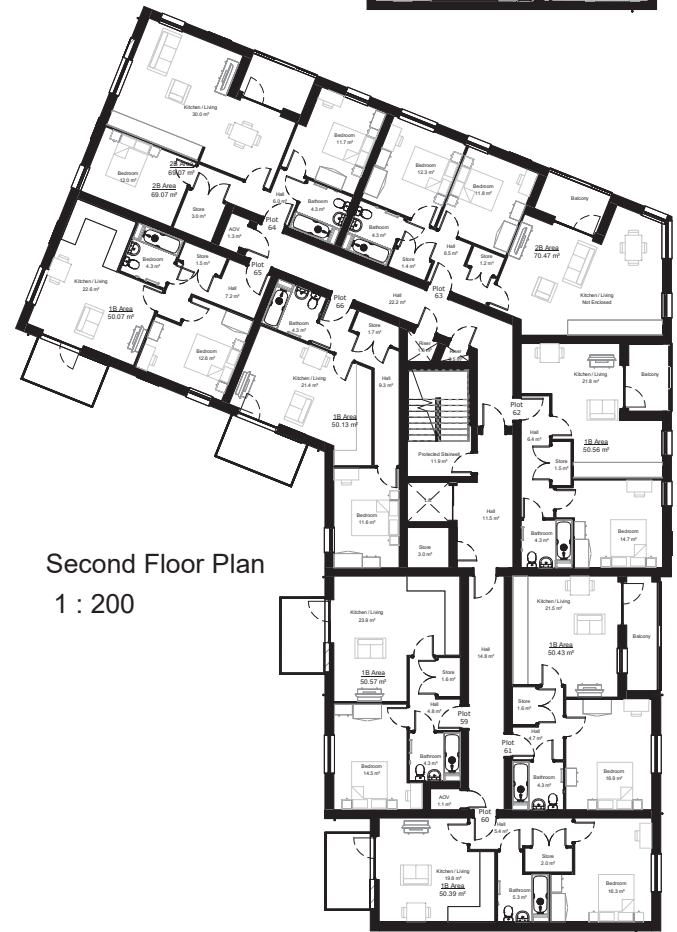
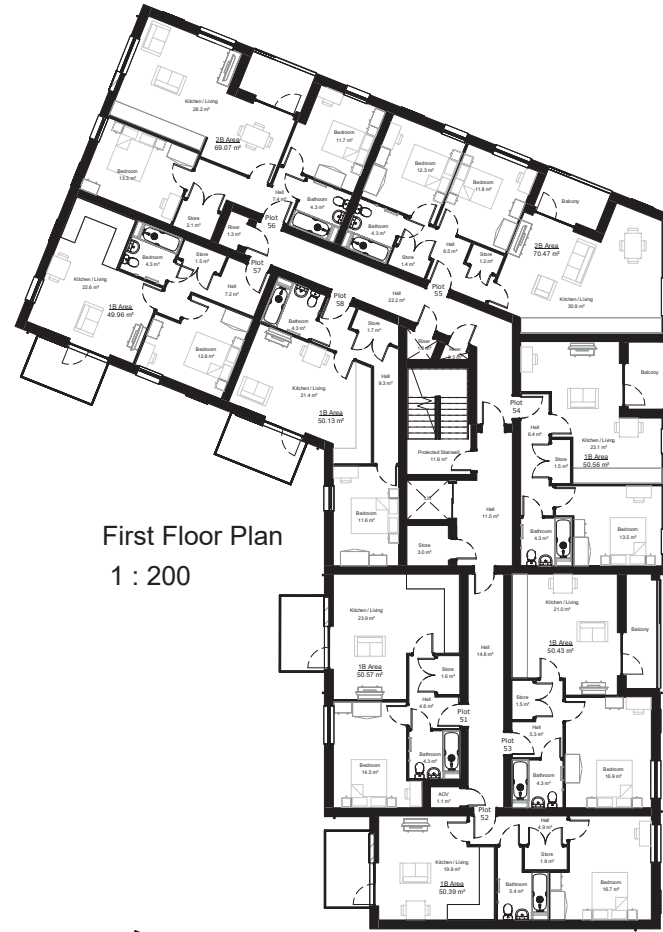

The proposed apartment comprises a total of 25 homes, featuring a diverse mix of unit types. The distribution of units is as follows:

- 15 x 1 bedroom
- 8 x 2 bedrooms
- 1 x 2 bedrooms M4(3)
- 1 x 3 bedrooms M4(3)

All five ground floor apartments have individual doors to ensure a sense of privacy. Additionally, there are no north-facing single-aspect flats, contributing to a well-balanced orientation throughout the building. All homes are designed to follow M4(2) standards, and there are 2 M4(3) homes per policy requirement.”

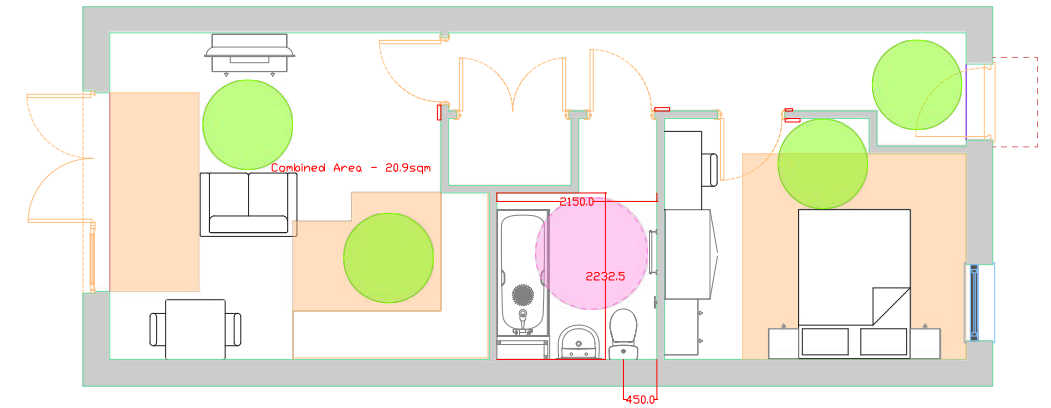

EXAMPLE OF GROUND FLOOR - 1 BEDROOM APARTMENT

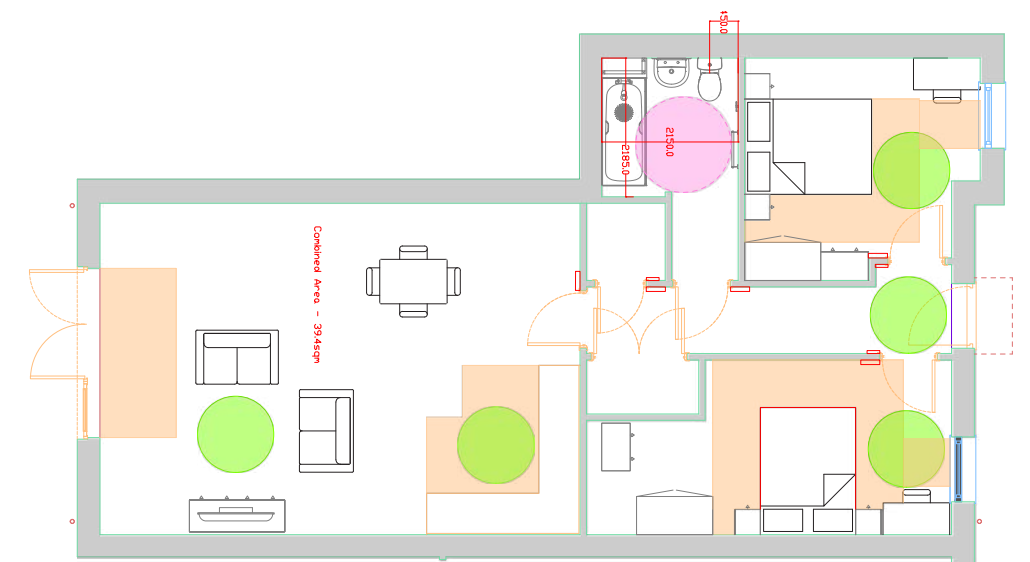

EXAMPLE OF GROUND FLOOR - 2 BEDROOM APARTMENT

PROPOSED ELEVATIONS - APARTMENT

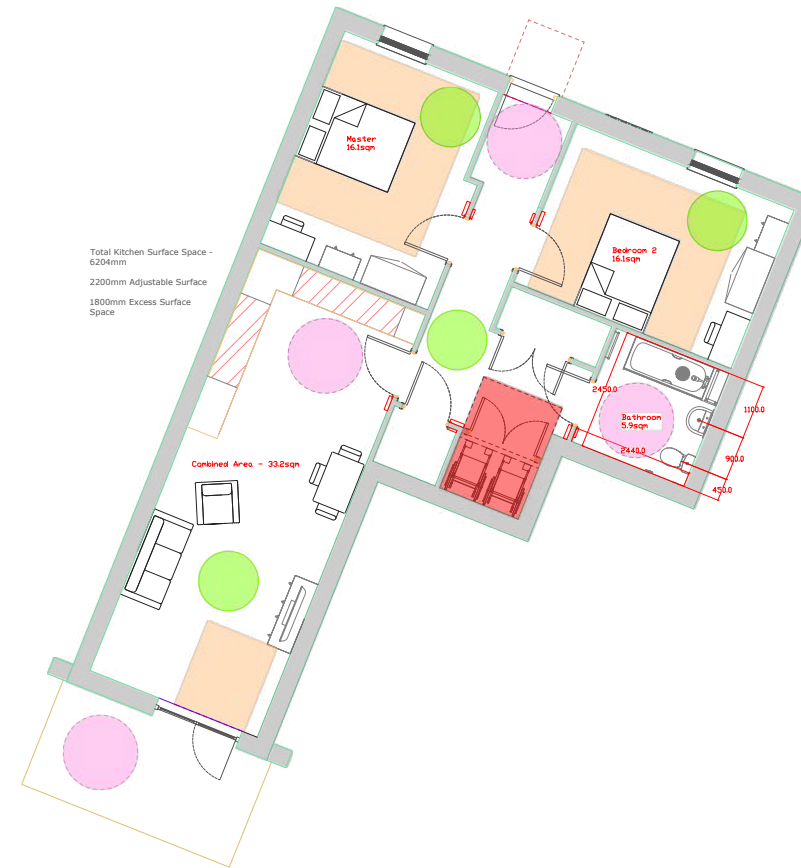

FLOOR PLAN OF 2 BEDROOM M4(3) APARTMENT



FLOOR PLAN OF 3 BEDROOM M4(3) APARTMENT

AFFORDABLE HOUSE

Affordable
3 Bedroom, 5 Person
Floor Area: 107.1sqm

M4(2)NDSS

Plots: 6,7,8

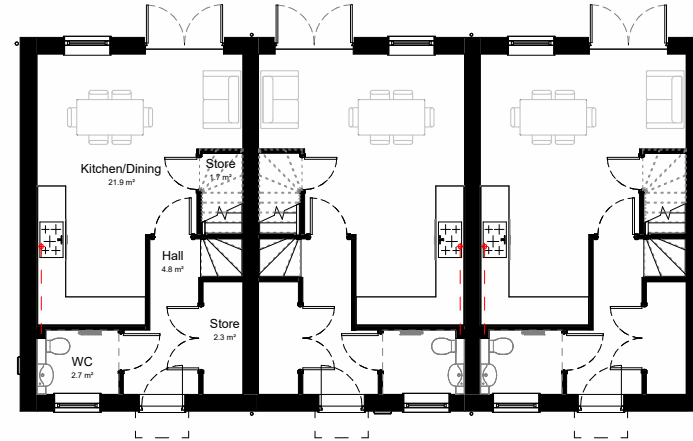

Ground Floor
1 : 100

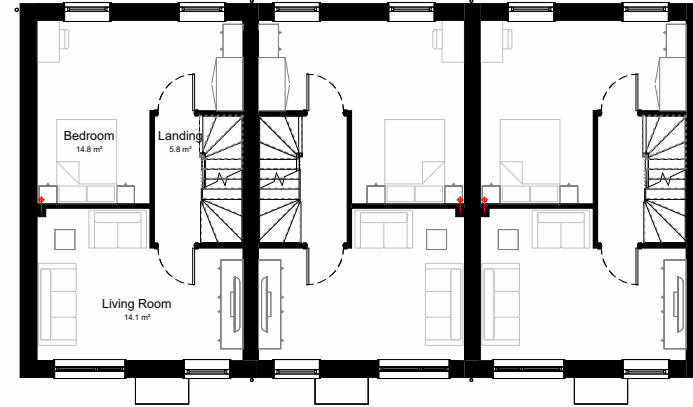

First Floor
1 : 100

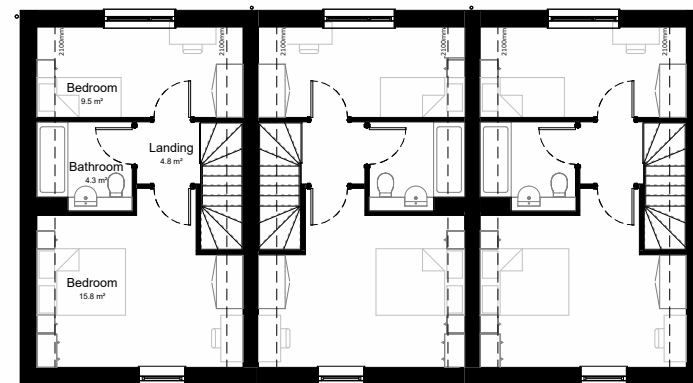

Second Floor
1 : 100

EXAMPLE OF PRIVATE HOMES - 2 BED & 3 BED HOUSE

Schedule of Revisions			
Rev.	Description	Date	Initial

Market Sale

3 Bedroom, 6 Person Floor Area: 119.1sqm

2 Bedroom, 4 Person Floor Area: 102.3 sqm

Plots: 15, 16, 17, 18

M4(2) NDSS

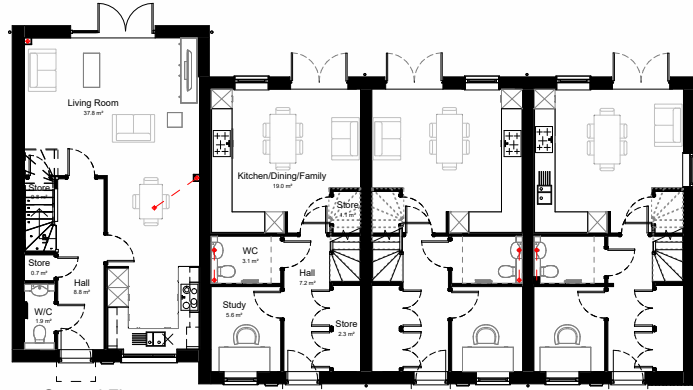

Ground Floor
1 : 100

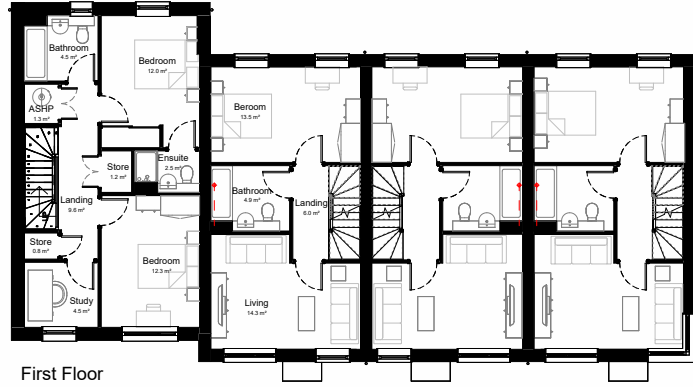

First Floor
1 : 100

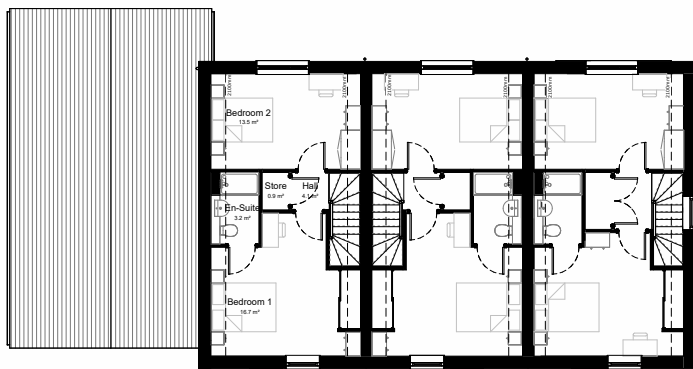

Second Floor
1 : 100

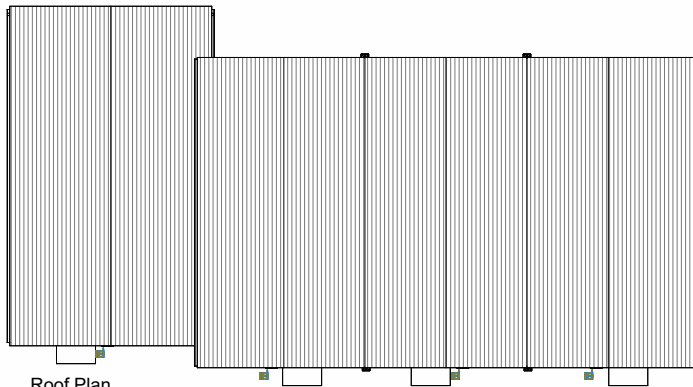

Roof Plan
1 : 100



Front Elevation
1 : 100

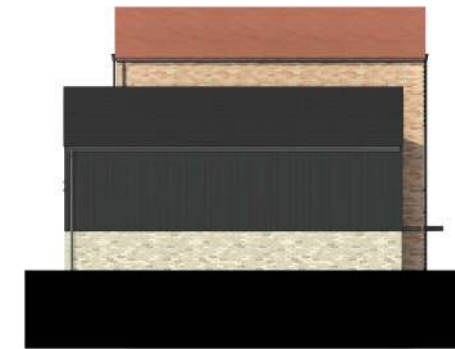

Side Elevation - Right
1 : 100



Rear Elevation
1 : 100



Side Elevation - Left
1 : 100

- 1 Roof Tiles - Red
 - 2 Roof Tiles - Grey
 - 3 Facing Brickwork 1 - Grey/Black/White Mix
 - 4 Facing Brickwork 2 - Red Mix
 - 5 Facing Brickwork 3 - White/Grey Mix
 - 6 Timber Cladding 1 - Black
 - 7 Extruded Black Brick details
 - 8 Corner Window
 - 9 Balcony - Metal Railing - Black/Grey
 - 10 Winter Garden - Glass / Panel Enclosed
 - 11 Brick Banding - Single Row, Alternating Brick Courses
 - 12 Metal Louvered Panel Black/Grey
 - 13 Brickwork Ventilation Details
 - 14 Privacy Panel
 - 15 Single Course Brick Band Black
 - 16 Triple Brickwork Header
 - 17 Obscured Glazing for Bin and Cycle Stores
 - 18 Door With Louvered Panel to Bin / Bike Store
 - 19 Metal Panelling Black/Grey
- Notes:
- Doors - Black/Grey
 - Windows - Aluminium framed - Black/Grey
 - Canopies - Metal - Black/Grey
 - Balcony - Metal - Black/Grey
 - Coping - Metal - Black/Grey
 - Rainwater Goods - Black/Grey
 - All WC / Bathroom Windows to be Obscured

EXAMPLE OF PRIVATE HOMES - 3 BED & 4 BED HOUSE

Market Sale
 4 Bedroom, 7 Person + Study
 Floor Area: 155.7 sqm
 -
 3 Bedroom, 6 Person + Study
 Floor Area: 142.9sqm
 M4(2) NDSS
 Plots: 33-34*, 41-42
 * Denotes Handed Unit

Schedule of Revisions			
Rev:	Description:	Date:	Initial:

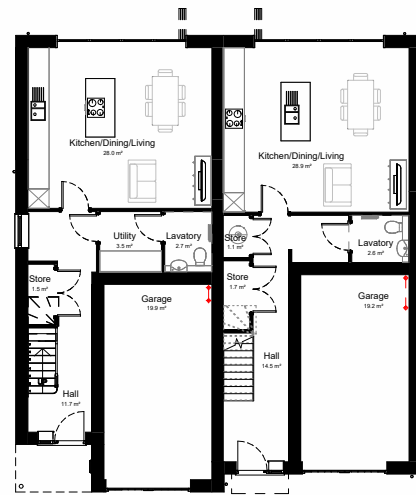

Ground Floor Plan
1 : 100



First Floor Plan
1 : 100

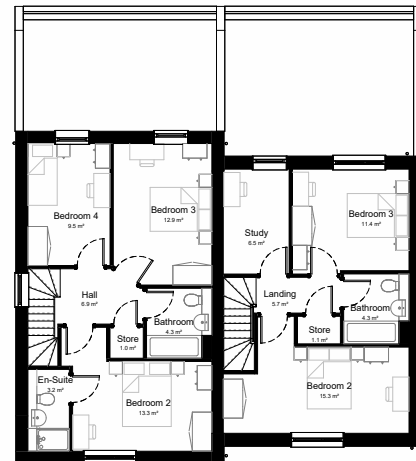

Second Floor Plan
1 : 100



Front Elevation
1 : 100

Side Elevation - Left
1 : 100



Rear Elevation
1 : 100

Side Elevation - Right
1 : 100

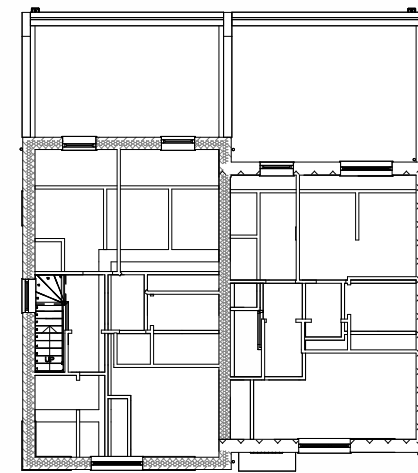

Roof Plan
1 : 100

- Roof Tiles - Red
 - Roof Tiles - Grey
 - Facing Brickwork 1 - Grey/Black/White Mix
 - Facing Brickwork 2 - Red Mix
 - Facing Brickwork 3 - White/Grey Mix
 - Timber Cladding 1 - Black
 - Extruded Black Brick details
 - Corner Window
 - Balcony - Metal Railing - Black/Grey
 - Winter Garden - Glass / Panel Enclosed
 - Brick Banding - Single Row, Alternating Brick Courses
 - Metal Louvered Panel Black/Grey
 - Brickwork Ventilation Details
 - Privacy Panel
 - Single Course Brick Band Black
 - Triple Brickwork Header
 - Obscured Glazing for Bin and Cycle Stores
 - Door With Louvered Panel to Bin / Bike Store
 - Metal Panelling Black/Grey
- Notes:
- Doors - Black/Grey
 - Windows - Aluminium framed - Black/Grey
 - Canopies - Metal - Black/Grey
 - Balcony - Metal - Black/Grey
 - Cladding - Metal - Black/Grey
 - Rainwater Goods - Black/Grey
 - All WC / Bathroom Windows to be Obscured

7.5 BUILDING RELATIONS

We examined the relationship between the existing and proposed buildings and made deliberate design choices to enhance the overall setting of the area for both future and existing residents.

- The removal of existing buildings has already improved the settings of Master House, Apartment B
- We lowered the site level (about 1m) on the northwest corner to reduce the mass of the proposed development.
- Proposed buildings on the northwest corner are positioned at least 11m meters away from existing buildings to create a buffer area between them.
- The buffered zone is enhanced with hedges and proposed trees.
- The side elevation of Plot 18 and 17 are both 2 storey and designed to avoid create an impact to Apartment C & A
- The distance between Plot 18 and Number 1 Seaby's Yard is minimum 19 meters.
- Proposed homes on Plot 42, 43, and 45 are situated 13 meters away from existing houses at 129-133 Histon Road



EXISTING BUILDINGS
TO BE REMOVED

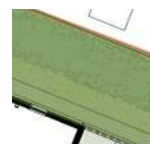

PROPOSED BUFFER ZONE



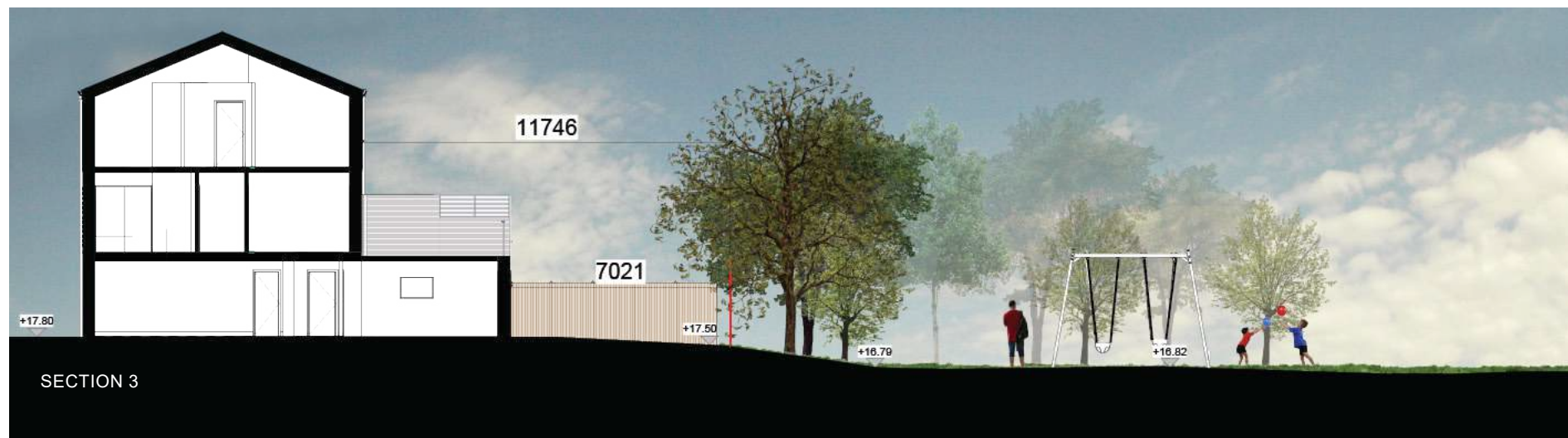
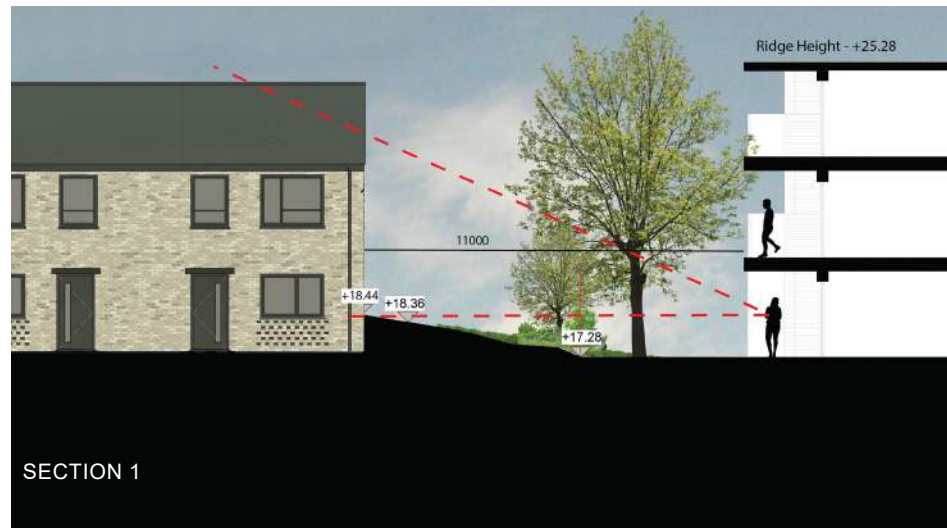



7.6 STREET SCENES & 3D VIEWS



BIRD'S EYE VIEW - PROPOSED



SITE ENTRANCE - CYCLE STORAGE AT THE CORNER



SITE ENTRANCE - 2



SITE ENTRANCE - 3

7.6 STREET SCENES & 3D VIEWS



VIEW TOWARDS - PARK LINK 2 & EAST



VIEW FROM APARTMENT A



TRANSITION BETWEEN HOUSES & APARTMENT



VIEWS TOWARDS PARK - GREEN LINK

7.6 STREET SCENES & 3D VIEWS

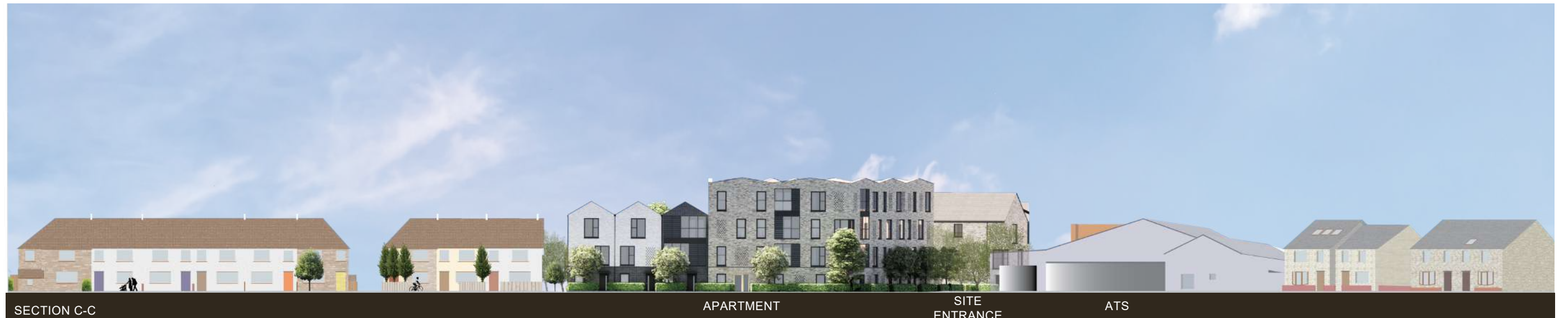

7.7 TREES



LEGEND	
	Existing Tree/Feature BS 5837:2012 Category A
	Existing Tree/Feature BS 5837:2012 Category B
	Existing Tree/Feature BS 5837:2012 Category C
	Existing Tree/Feature BS 5837:2012 Category U
	Line of Root Protection Area (RPA) - calculated following guidelines set in BS 5837:2012
	Existing Tree/Feature to be Removed BS 5837:2012 Category U
	Additional feature which doesn't meet BS 5837:2012 categorisation but is included for reference
	Forecasted crown spread

7.8 DRAINAGE

- We are currently conducting a comprehensive analysis of the urban site, considering existing infrastructure, topography, and soil permeability.
- All roads will have permeable and will offer storage and treatment to surface water
- We proposed to place underground storage crates beneath impermeable surfaces (e.g., parking lots, roads). The system will provide storage below ground for the 1% event + climate change.
- Water reuse facilities will be provided, such as the inclusion of water butts for every residence
- By implementing these measures, the urban site can effectively manage stormwater, mitigate flooding risks, and contribute to a more sustainable and resilient urban environment.

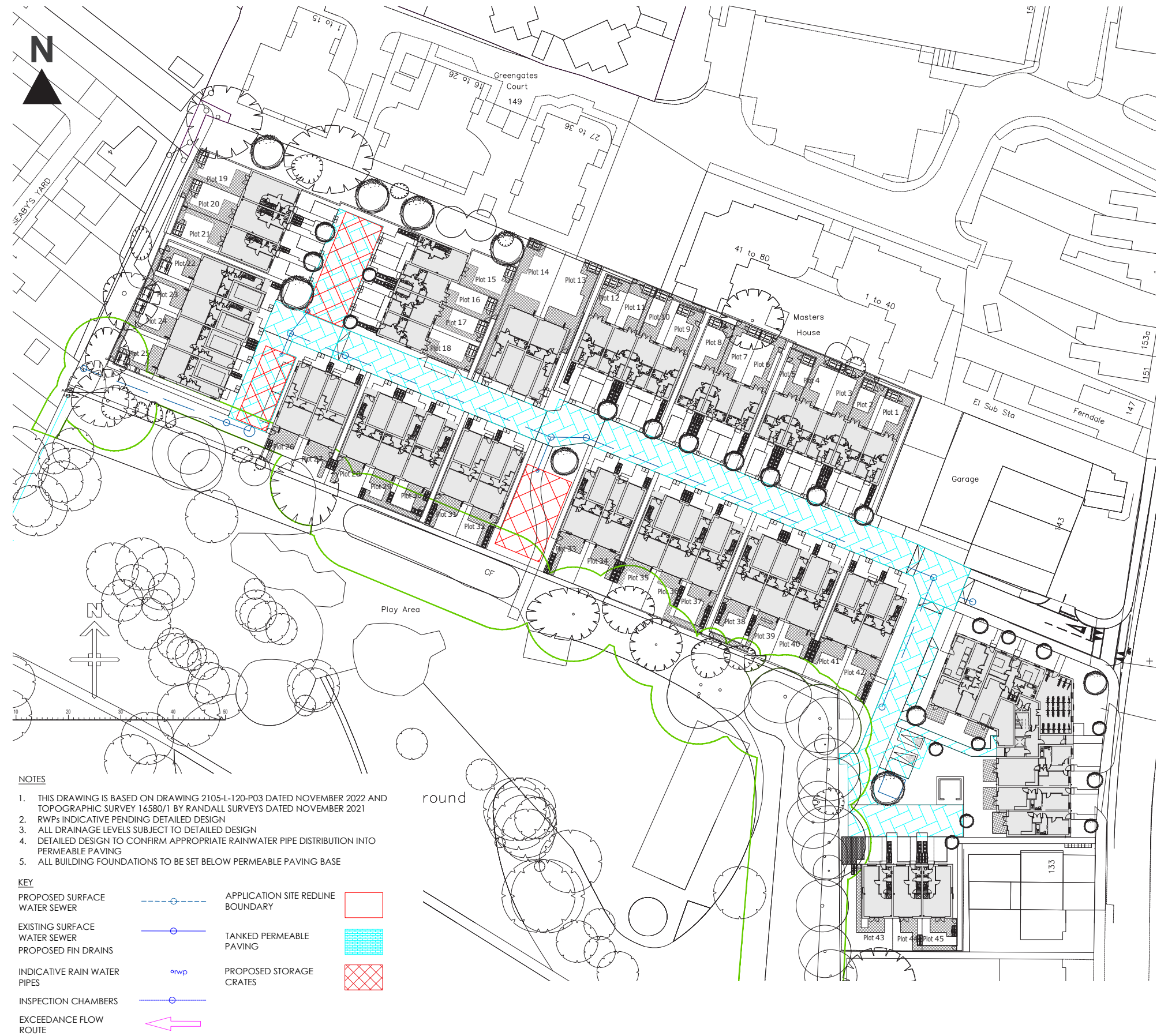

8.0 CONCLUSION







Cambridge
Investment
Partnership

The Hill Group
The Power House
Gunpowder Mill

Powdermill Lane
Waltham Abbey

EN9 1BN

t: 0208 527 1400

e: headoffice@hill.co.uk

www.hill.co.uk